



"HENRI COANDA"
AIR FORCE ACADEMY
ROMANIA



"GENERAL M.R. STEFANIK"
ARMED FORCES ACADEMY
SLOVAK REPUBLIC

INTERNATIONAL CONFERENCE of SCIENTIFIC PAPER
AFASES 2012
Brasov, 24-26 May 2012

CONTROL SYSTEM FOR A SINGLE SPOOL JET ENGINE WITH VARIABLE-AREA EXHAUST NOZZLE

Alexandru Nicolae TUDOSIE*, Constantin Lucian SEPCU*

*Electrical, Power Systems and Aerospace Engineering Department, University of Craiova, Romania

Abstract: *This paper presents an aircraft single-spool jet engine with variable-area exhaust nozzle as controlled object. The authors have identified a possible control structure based on two input parameters (fuel flow rate Q_c and nozzle's exhaust area A_5), respectively two output parameters (speed n and combustor gas temperature T_3^*). One has defined an engine control system structure and one has also established its mathematical model, based on some previous contributions and experimental works (having as subject a VK-1-type jet engine). Some simulations, concerning engine's step input response, were performed, in order to establish engine's quality. The employed method and some of the obtained results could be extended for further studies (such as twin spool jet engines, or jet engines with afterburning).*

Keywords: *jet engine, spool, nozzle, control, model, speed, temperature.*

1. INTRODUCTION

The engines for modern aircraft, especially the ones for combat aircraft, must assure high level of thrust, low time response and maneuverability. For an engine high thrust level, there are necessary high compressors pressure ratios π_c^* , high combustor burned gas temperatures T_3^* , as well as alternative thrust augmentation methods (such as afterburning, compressor or combustor water injection).

Aircraft jet engines as controlled objects are studied in [7,9,10], where the authors have identified, amongst a multitude of parameters, possible control parameters (inputs), possible controlled parameters (outputs), as well as theoretical command laws.

As input parameters, one has identified

only three: a) the combustor fuel flow rate Q_c (for all engine types); b) the exhaust nozzle's opening A_5 (only for engines with variable-area nozzles); c) the afterburner fuel flow rate Q_p (only for the engines with afterburning).

Jet engines for aircraft are built in a large range of performances and types (such as single- or double-spool, single jet or twin jets, with or without afterburning). Different types of fuel pumps assure their fuel supply: with plungers, with pinions (toothed wheels), or with impeller. For all of them, the output fuel flow rate depends on their rotation speed and on their actuator's position; for the pump with plungers the actuator gives the plate's cline angle, but for the other pump type the actuator determines the by-pass slide-valve position (which gives the size of the discharge orifice,

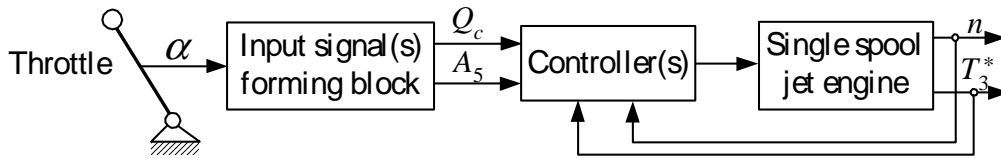

Figure 1. Engine control scheme

that means the amount of the discharge fuel flow rate).

Usually, fuel pumps are included in the jet engine's control system; more precisely: the fuel pump is turned round by the engine's shaft (obviously, through a gear box), so the pump speed is proportional (sometimes equal) to the engine's speed n , which is the engine's most frequently controlled parameter. So, the other pump control parameter (the plate angle or the discharge orifice width) shall be issued by the engine's speed controller [2,11].

Engine's speed controllers are built based on various operating principles, in a large range of types. Mostly all of them are controlling the engine speed using as main parameter the injected fuel flow rate [2,9,10,11,12].

Engine's exhaust nozzle's opening control systems are presented in [4,10,13], being designed as follower systems (in order to reproduce the desired A_5 with respect to the throttle's position).

This paper's aim is to build a model for a single spool jet engine with two input parameters, based on previous theoretical and/or experimental control schemes.

2. ENGINE'S CONTROL SCHEME

Single spool jet engine's most important outputs (controlled parameters) are [6,7,9,10]: spool (shaft) speed (also called engine speed)

n and combustor hot gases temperature T_3^* . As inputs (control parameters), one can use the fuel flow rate Q_c and the nozzle's gas exhaust area A_5 . Possible mixed control schemes, using the above-mentioned parameters, are presented in [9,10]. Although, the aircraft's pilot has at his disposal only the throttle (as possibility to control the engine). Consequently, the throttle has to generate somehow, by its displacement, the input signals forming, which means that engine input parameters Q_c and A_5 should be determined as some other control systems' outputs (as figure 1 shows).

Combustor gases temperature T_3^* is very difficult to be measured and to be used as control/controlled parameter; instead of T_3^* nowadays jet engines' measured temperature is the more accessible T_4^* temperature, behind the turbine. Even so, the gas temperature is rarely used as controlled parameter, at most as limited parameter, its control being accomplished by a distinct system, involving the injection fuel flow rate;

This paper deals with an embedded control system for a single-spool jet engine with variable-area nozzle. Engine's control system is depicted in figure 2 and consists of two sub-systems: the first one is meant to establish the injection fuel flow rate, the second one (a follower system) is meant to co-relate the exhaust nozzle's area to the throttle's position.

The first sub-system is the engine speed

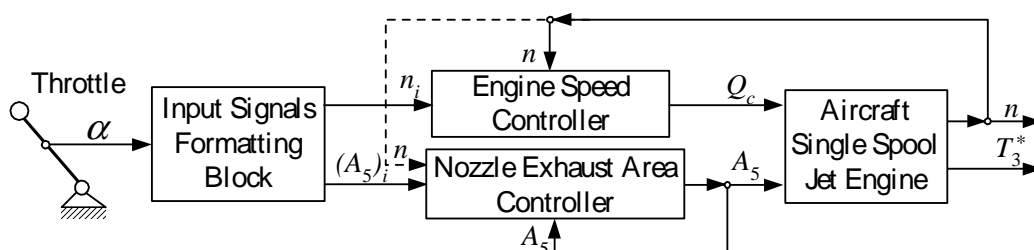

Figure 2. Single spool jet engine control system scheme

control system; such controllers were described in [2,11,12]. The second sub-system, for the nozzle's area control, is a follower-one, described in [13] (or similarly in [4] and [10]).

The system in figure 2 can be improved, for its operational security, if one uses a temperature controller (a system which discharges a fraction of the injected fuel flow rate when the highest admissible T_3^* or T_4^* temperature value is overflowed)

An operational block-diagram of the described system is the one in figure 3.

3. SYSTEM'S MATHEMATICAL MODEL

The above described system is built-up of three main parts: the engine, the speed controller and the exhaust nozzle's controller; their reunited motion equations are building the system's mathematical model.

3.1 Jet engine's model, determined and described in [7], consists of two equations, one for the engine's speed, the other for the combustor's temperature, both of them with respect to the fuel flow rate and to the exhaust nozzle's area, as follows

$$(\tau_m s + 1)\bar{n} = k_c \bar{Q}_c + k_{nA5} \bar{A}_5 - k_{HV} \bar{p}_1^*, \quad (1)$$

$$(\tau_m s + 1)\bar{T}_3^* = k_{T3c} (\tau_{Tc} s + 1) \bar{Q}_c + k_{TA5} (\tau_{TA} s + 1) \bar{A}_5 - k_{TH} (\tau_{Tp} s + 1) \bar{p}_1^*, \quad (2)$$

where τ_m is the engine's time constant, τ_{Tc} , τ_{TA} , τ_{Tp} – model time constants, $k_c, k_{nA5}, k_{HV}, k_{T3c}, k_{TA5}, k_{TH}$ – gain co-efficient.

The terms containing \bar{p}_1^* are describing the flight regime disturbances effects.

3.2 Engine speed controller's model, determined and described in [11], consists of

a) fuel pump's equation (with respect to its speed n and to its actuator position y)

$$\bar{Q}_c = k_{pn} \bar{n} + k_{py} \bar{y}, \quad (3)$$

b) actuator's equations

$$\bar{x} = k_u \bar{u} - k_{es} \bar{n}, \quad (4)$$

$$\tau_s \bar{y} = \bar{x} - \bar{z}, \quad (5)$$

c) rigid feed-back equation (for z)

$$\bar{z} = \rho_s \bar{y} \quad (6)$$

where τ_s is the actuator's time constant, k_{pn} , k_u, k_{es} – gain co-efficient, ρ_s – feed-back gain.

3.3 Exhaust nozzle controller's equations, as determined in [13], with respect to throttle lever's position (θ) and to the supplying pressure (p_g) are, as follows

$$\bar{A}_5 = k_{5y} \bar{y}_A, \quad (7)$$

$$\bar{y}_A = \frac{(\tau_{u\theta} s + \rho_\theta) \bar{\theta} + (\tau_{ug} s + \rho_g) \bar{p}_g}{(\tau_{yA} s + 1)(\tau_{uA} s + 1)}, \quad (8)$$

where the above annotations have the forms presented in [13].

Together with the above-mentioned eight equations, one has to consider both input signals formatting block's equations

$$\bar{\theta} = k_{\alpha\theta} \bar{\alpha}, \quad (9)$$

$$\bar{u} = k_{\alpha u} \bar{\alpha}, \quad (10)$$

(where α is the engine throttle's position angle, $k_{\alpha\theta}, k_{\alpha u}$ – gain co-efficient) and hydraulic supply equations. As shown in [9,10], the hydraulic pump is connected to the

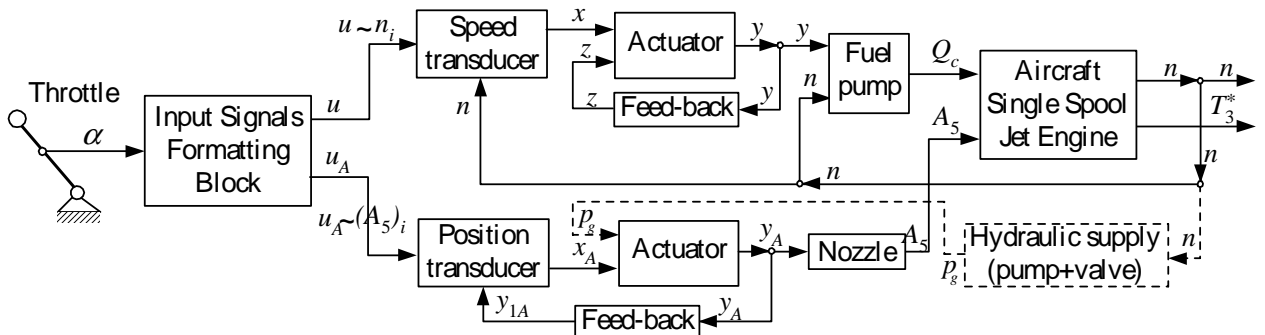

Figure 3. Single spool jet engine control system's operational diagram

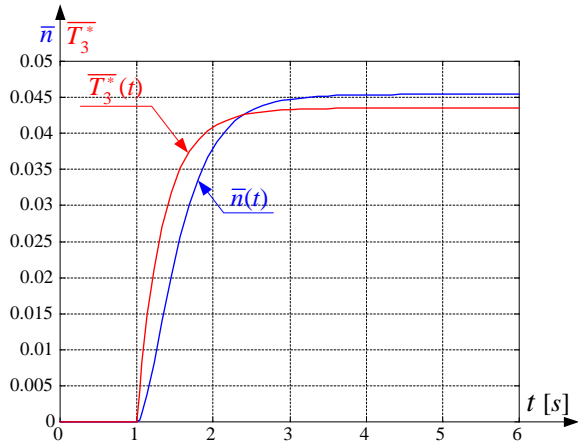

Figure 5. Time response of a single spool jet engine with variable-area nozzle for α step input

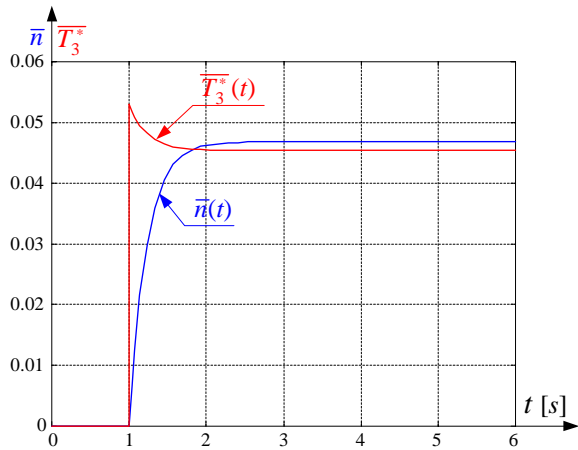

Figure 6. Time response of a single spool jet engine with constant area nozzle for α step input

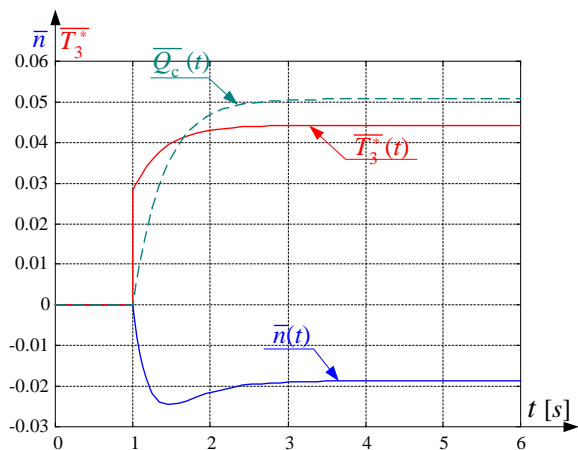

Figure 7. Step response for both inputs (throttle $\bar{\alpha}$ and flight regime \bar{p}_1^*)

system behavior, concerning both parameters and their monitored aspects (stability type, static error and time of stabilization).

Therefore, when the flight regime becomes more intense (flight speed increases and/or flight altitude decreases), because of the engine's speed controller design, speed parameter \bar{n} should remain constant [10,11]; although, its stabilization to a new regime realizes, periodic-type, with a small initial overflow and with a small negative static error (-1.8%).

One can also observe that, in order to keep the same speed level, as well as the same thrust, the fuel flow rate has to grow (as the dashed curve in figure 7 shows); meanwhile, as consequence, the combustor's temperature parameter \bar{T}_3^* level grows too, with an initial step growing, followed by an aperiodic stabilization; the static error is nearly the same (positive, around 4.5%). The stabilization times remain practically the same as in the first case.

5. CONCLUSIONS

The authors have studied a single-spool jet-engine (VK-1 type), with variable-area exhaust nozzle and mixed control system.

The studied embedded control system was described both as mathematical model and as block diagram with transfer functions; based on it, one has performed some simulations, in order to determine system's quality (time behavior for step input(s)).

The simulations results have shown a stable system, no matter were the studied situation. Although, comparing figure 5 and 6, one can affirm that the engine with variable-area exhaust nozzle has nearly the same behavior as the same engine with constant area nozzle, from the speed's parameter point of view; the difference is made by the combustor temperature, which has a jump and an overflow in the second case. One can affirm that the exhaust variable area nozzle's presence improves the system's behavior from the temperature's point of view.

The above-presented mathematical model and the block diagram with transfer functions can be formally used for other similar single-spool single-jet engines, being necessary the

co-efficient calculus (co-efficient involved in eq. (1) to (12), having the forms determined in the referenced papers).

The same mathematical model can be completed with the appropriate equations, in order to make it useful for a study of a single spool single jet engine with afterburning, or it can be extended, with appropriate chosen modifications, to the twin spools jet engines.

REFERENCES

1. Abraham, R. H., *Complex dynamical systems*. Santa Cruz, California, USA: Aerial Press (1986).
2. Lungu, R., Tudosie, A.. Single Spool Jet Engine Rotation Speed Control System, Based on Fuel Flow Rate Control. *Proceedings of the XXVII-th Scientific International Session of the Military Technical Academy*, Bucharest: Issue (1997).
3. Lungu, R., *Flight Apparatus Automation*. Universitaria, Craiova, (2000).
4. Lungu, R., Tudosie, A., Corcau, J. Automatic control system for the exhaust nozzle flaps positioning. *Constructia de masini*, Bucharest: Issue (2001).
5. Mattingly, J. D., *Elements of Gas Turbine Propulsion*. New York, USA: McGraw Hill (1996).
6. Pimsner, V., *Air-breathing Jet Engines. Processes and Characteristics*. Bucharest, Romania: Didactic and Pedagogic Publishing (1983).
7. Stoenciu D., *Aircraft Engine Automation. Aircraft Engines as Controlled Objects*. Bucharest: Military Technical Academy Inprint (1977).
8. Stoenciu D., *Aircraft Engine Automation. Catalog of Automation Schemes*. Bucharest: Military Technical Academy Inprint (1986).
9. Stoicescu M., Rotaru, C., *Turbo-Jet Engines. Characteristics and Control Methods*. Bucharest: Military Technical Academy Inprint (1999).
10. Tudosie, A. N., *Aerospace Propulsion Systems Automation*. Craiova: University of Craiova Inprint (2005).
11. Tudosie, A.. Automatic hydro-mechanical control system for a jet engine's rotation speed. *Proceedings of the Scientific Session "25 Years of High Education in Arad"*. Issue (1997).
12. Tudosie, A.. Hydro-mechanical Jet Engine's Speed Controller Based on the Fuel's Injection Pressure's Control. *WSEAS Transactions on Systems*. Issue (2008).
13. Tudosie, A.. Aircraft Jet Engine Exhaust Nozzle Hydromechanical Automatic Control System. *International Conference of Scientific Paper AFASES 2012*. Issue (2012).