



"HENRI COANDA"  
AIR FORCE ACADEMY  
ROMANIA



"GENERAL M.R. STEFANIK"  
ARMED FORCES ACADEMY  
SLOVAK REPUBLIC

INTERNATIONAL CONFERENCE of SCIENTIFIC PAPER  
AFASES 2015  
Brasov, 28-30 May 2015

## THE INFLUENCE HEAT TRANSFER COEFFICIENT ON WOOD CONSTRUCTION

Cosmin Spîrchez\*, Aurel Lunguleasa\*

\*Faculty of Wood Engineering, Transilvania University of Brasov, Romania

**Abstract:** *The paper presents types of insulation materials and their importance on wooden construction. Using computer software allowed the determination of heat transfer coefficient. The heat transfer coefficient has great importance for wood construction.*

**Keywords:** *insulation material, wood, heat transfer coefficient*

### 1. INTRODUCTION

Green buildings are considered to be those that simultaneously meet the following conditions [1]:

- Have a constructive and functional structure and a process for achieving that don't contribute to environmental degradation (built and natural) and environmental factors.
- Allows efficient use of resources (water, energy) throughout the entire lifecycle.
- Meeting the technical requirements of the design and use, as well as the strength and stability, fire protection, health protection.
- Can carry and use with costs borne by investors.
- Meet the needs or expectations of the user from the sustainability, efficiency, comfort, and aesthetics.

Natural constructions are a similar concept in practice applied mainly small-scale and are characterized by:

- The use of natural buildings materials.

- Using materials and methods, manufacturing techniques near the place of their establishment and functioning.

Natural building concept corresponds to practice organic architecture and green architecture [1].

### 2. INSULATION MATERIALS USED TO WOOD CONSTRUCTION

#### Natural fiber insulation:

- sheep wool insulation;
- hemp fiber insulation;
- wood fiber insulation.

**Sheep wool insulation** is manufactured from natural wool fibers, washed and treated. These wool fibers are held either mechanically or using a maximum of 12% polystyrene fibers to form sheets or rolls.

Wool insulation is used as heat and sound insulation. Wool is a hygroscopic material which means that it is designed to absorb up to 30-40% of its own weight in moisture content. Thermal conductivity is between 0.0356

W/mK-0,040 W/mK. Sheep wool insulation is fire resistant[1].

**Hemp fiber insulation.** Insulation is manufactured from hemp fiber plus 10-12% Biko fibers for excellent dimensional stability.

Recently appeared insulation that is 100% natural hemp fibers Biko optional when natural fibers are replaced with corn[1].

Hemp is capable of absorbing up to 20% of its weight in moisture content. Hemp fiber insulation has low conductivity of 0.040 W/mK.

**Wood fiber insulation.** Raw materials for manufacture of insulated panels are wood fiber waste from wood chips.

Wood fibers obtained from wood chips can be treated by up to 2% paraffin.

Roofs are building elements serving the protection at the top of the building against climate action.

To perform this operation, the roof must ensure the collection and removal of meteoritic water, in order to prevent damages that may occur in their penetration into the building.

Roofs are divided into 2 groups: framing roofs, terrace roofs [2].

Roof framing type includes the following elements are: roof covering, elements accessories.

In fig.1 presents longitudinal framing walls for  $11.00\text{ m} < L < 13.00\text{ m}$ .

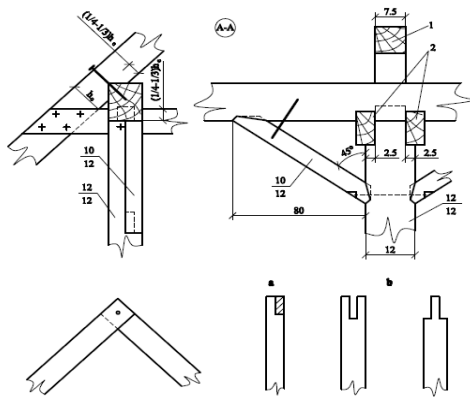

Fig. 1 Longitudinal framing walls for  $11.00\text{ m} < L < 13.00\text{ m}$

- 1- rafter;
- 2- plier (7.5 \* 15);

In fig.2 presents longitudinal framing walls for  $11.00\text{ m} < L < 13.00\text{ m}$ .

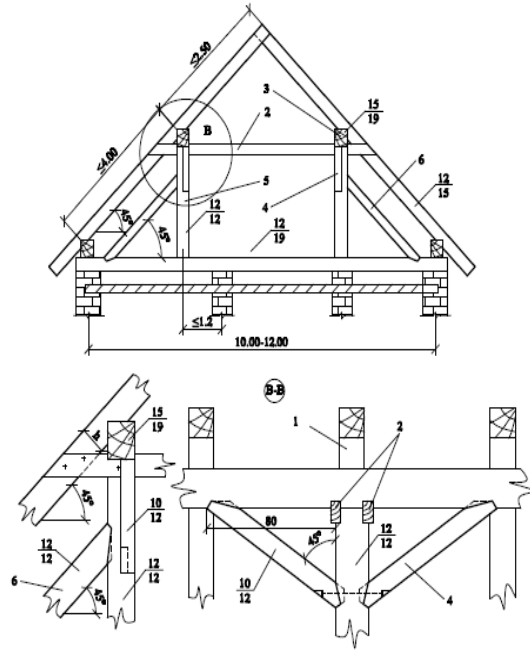

Fig.2 Longitudinal framing walls for  $11.00\text{ m} < L < 13.00\text{ m}$

- 1- rafter;
- 2- plier (7.5 \* 7.5);
- 3- base;
- 4- truss;
- 5- post.

In fig. 3 presents median longitudinal framing walls.

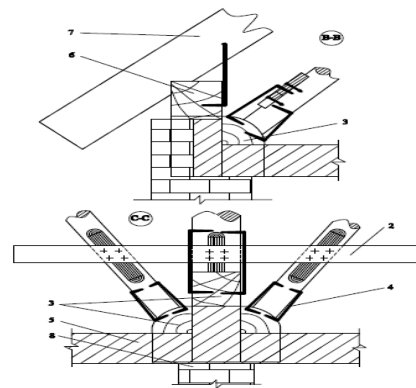

Fig.3 Longitudinal framing walls for  $9.00\text{ m} < L < 11.00\text{ m}$

In fig. 4 presents median longitudinal framing walls.



"HENRI COANDA"  
AIR FORCE ACADEMY  
ROMANIA



"GENERAL M.R. STEFANIK"  
ARMED FORCES ACADEMY  
SLOVAK REPUBLIC

INTERNATIONAL CONFERENCE of SCIENTIFIC PAPER  
AFASES 2015  
Brasov, 28-30 May 2015

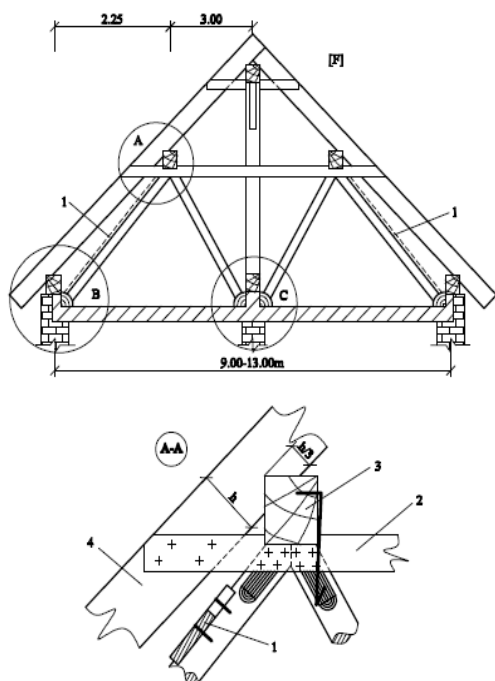

Fig. 4 Longitudinal framing walls for 9.00 m < L < 13.00 m

**3. OPTIMIZATION STRUCTURE FOR PASSIVE ENERGY HOUSE**

The paper has been taken to study three structures of insulation for passive energy house.

With software from German company ([www.u-wert.net](http://www.u-wert.net)) were mapped graphics on temperature variation profiles coefficients from moisture and heat [3].

The structure of 1 taken for analysis is made of MDF (thickness 16 mm, coefficient of thermal conductivity of 0.13 W / mK), hamp (thickness 100 mm, coefficient of thermal conductivity of 0.04 W / mK), OSB (thickness 12 mm, coefficient of thermal conductivity of 0.11 W / mK), climacell

(thickness 200 mm, coefficient of thermal conductivity of 0.04 W / mK).

Figure 5 shows the temperature variation of structure 1.

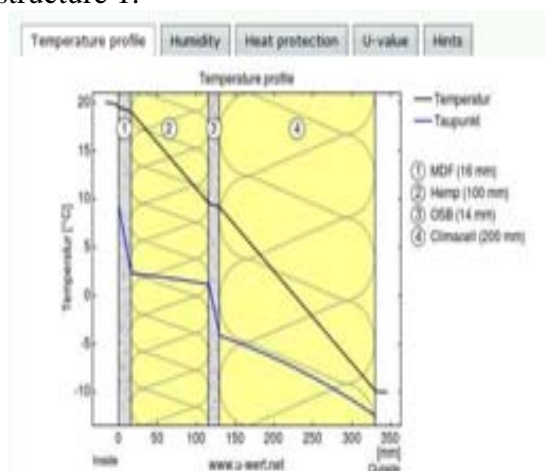

Fig. 5 Temperature variation for structure 1

In fig. 6 shows the variation thermic protection coefficients for structure 1.

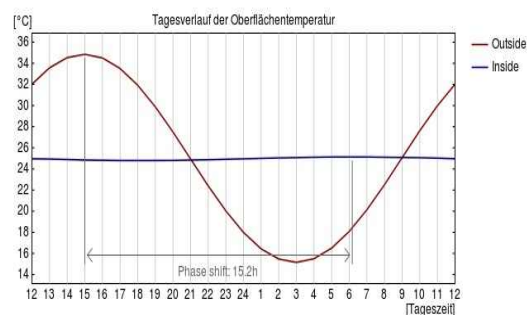

Fig. 6 Variation thermic protection coefficients for structure 1

The structure of 2 taken for analysis is made of gypsum fiberboard (thickness 16 mm, coefficient of thermal conductivity of 0.32 W/mK), KnaufTecTem (thickness 100 mm, coefficient of thermal conductivity of 0.045 W/mK), Gutex Multhiterm (thickness 14 mm, coefficient of thermal conductivity of 0.042 W / mK), Isocell (thickness 200 mm, coefficient of thermal conductivity of 0.04 W / mK).

Figure 7 shows the temperature variation of structure 2.

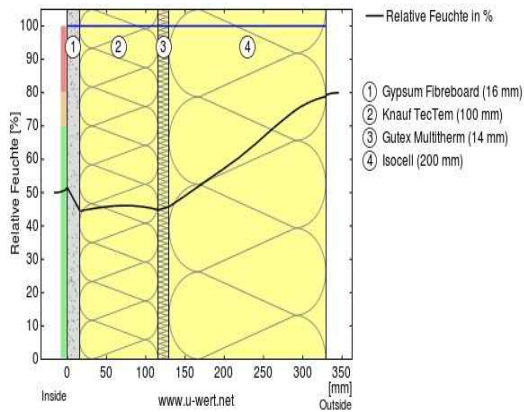

Fig.7 Temperature variation for structure 2

In fig.8 shows the variation thermic protection coefficients for structure 2.

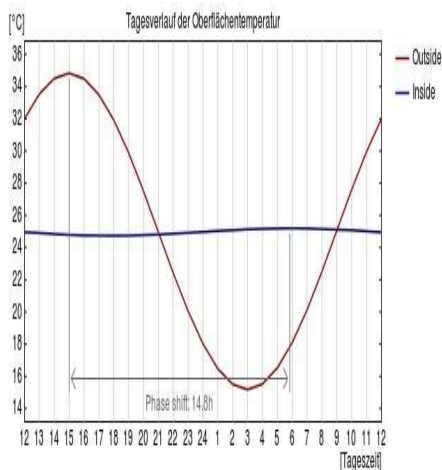

Fig.8 Variation thermic protection coefficients for structure 2

The structure of 3 taken for analysis is made of wool (thickness 16 mm, coefficient of thermal conductivity of 0.04W/mK), mineral (thickness 100 mm, coefficient of thermal conductivity of 0.045W/mK), cellulose (thickness 14 mm, coefficient of thermal conductivity of 0.04 W/mK), folio (thickness 200 mm, coefficient of thermal conductivity of 0.22 W / mK).

Figure 9 shows the temperature variation of structure 3.

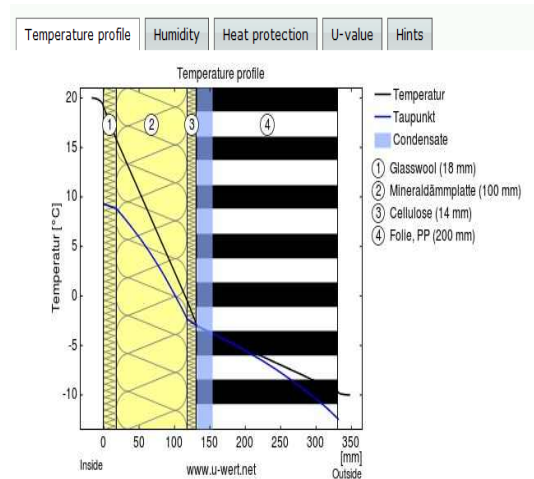

Fig.9 Temperature variation for structure 3

In fig.10 shows the variation thermic protection coefficients for structure 3.

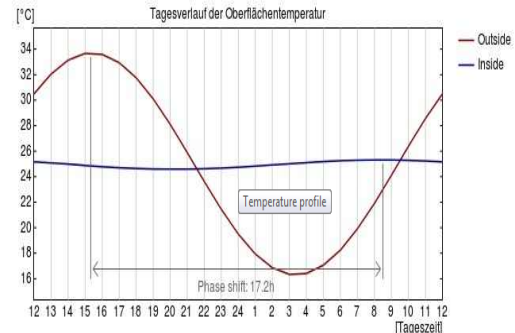

Fig. 10 Variation thermic protection coefficients for structure 3

#### 4. CONCLUSIONS

Given that structure 1 heat transfer coefficient  $U = 0.127 \text{ W/m}^2\text{K}$ , structure 2 is the heat transfer coefficient  $U = 0.128 \text{ W/m}^2\text{K}$ , structure 3 is the heat transfer coefficient  $U = 0.244 \text{ W/m}^2\text{K}$ . The optimum structure is 1.

A low U-value indicates a high level of insulation.

#### REFERENCES

1. Bucur, I., *Eco managementul cladirilor*. City Constanta: Publishing House (2002).
2. Lazarescu C-tin., *Constructii din lemn*, Brasov, Transilvania University of Brasov, Publishing House (2008).
3. Tutorial Program [www.u-wert.net](http://www.u-wert.net)