

AIRPLANE PROPELLERS AERODYNAMIC DESIGN AND PERFORMANCES ANALYSIS

Constantin ROTARU*, **Carmen ȘTEFAN****, **Gabriel RĂDUCANU*****,
Radu DINCĂ*

*"Henri Coandă" Air Force Academy, Brasov, Romania (rotaru.constantin@afahc.ro)

**Romanian Aviation Academy, Bucharest, Romania (carmen.garnita@gmail.com)

***Air Force Staff, Bucharest, Romania (gabiraducanu@yahoo.ca)

DOI: 10.19062/1842-9238.2017.15.1.12

Abstract: *The present paper analyzes the aerodynamic characteristics of aircraft propellers, starting from the operational requirements of the airplanes they are mounted on and some limitations related to the compressibility effect. The mathematical model for calculation of blade induced speed in the rotation movement is the one based on Goldstein's vortex theory, with approximation of proportionality constant of circulation with the one corresponding to the aerodynamic pitch angle at the tip of the blade. There has been written the integral form of propeller thrust and torque moment, and the dimensionless coefficients of blade and propulsive efficiency have been established. There have been highlighted differences from the fixed wing, with respect to the development of lift force, induced speed generation and limitations regarding the construction and operation of the propeller. Numerical solutions for establishing the thrust and power distribution along the propeller have been obtained for a propeller whose geometrical shape corresponds to a blade of a flight training plane.*

Keywords: *airplane propeller, aerodynamic design, pitch angle*

1. INTRODUCTION

The evolution of modern airplanes, their performances, stability and control are directly related on development and improvement of propulsion systems technology. The thrust, regarded as a reaction force is a result of the momentum and kinetic energy increase of the air which passes through the engine (inlet, compressor, combustion chamber, turbine and nozzle). Applying Reynolds Transport Theorem to a control volume that extends sufficiently far from the propulsion system, so that at the boundary enclosing this volume the air pressure is equal to the ambient (atmospheric) pressure, we have the equation of the thrust, T ,

$$T = \dot{m} (V_{exit} - V_{free\ stream}) \quad (1)$$

where \dot{m} is the mass flow rate, V_{exit} and $V_{free\ stream}$ are the velocities where the air exits and enters the control volume. The thrust developed by any propulsion system can be increased either by acting upon the mass flow rate or upon the velocity increment and based on the aircraft propulsion theory, the most increasing thrust is obtained by using a large mass flow rate with a small velocity increment (fig. 1). This requirement is accomplished by the engine-propeller system which produce relatively high flow rates because of the propeller large diameter, this type of propulsion system being the most efficient device commonly used for low speed subsonic flight [1].

One important development in aviation was the introduction of the variable-pitch and constant-pitch propellers, besides others improvements of blade aerodynamic shapes or of movement transmission mechanisms which connect the propeller and the reciprocating or turboshaft engines.

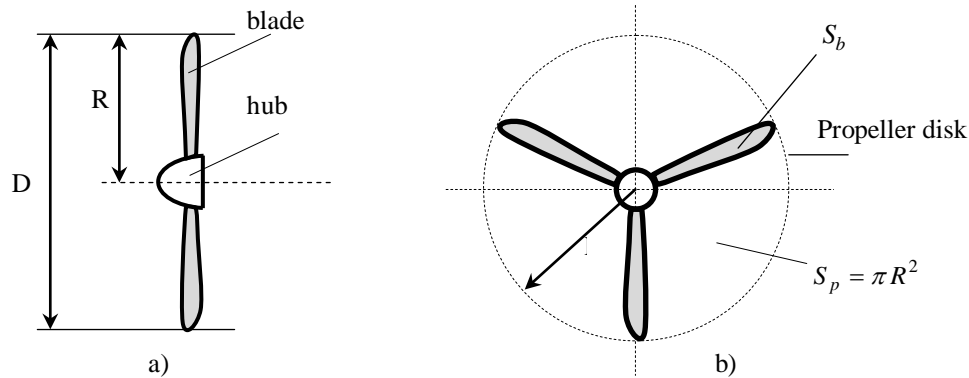

FIG. 1 Propeller geometry: a) lateral view, b) front view

The lift force developed by a wing is directed to support the airplane weight and keep it aloft, whereas the lift developed by a propeller is oriented with the direction of motion [2]. The relative airflow over a propeller blade is a result of its rotation movement, so that, the velocity of each section depends on the distance from the axis of rotation, the propeller blade having much more twist or geometric washout than a conventional wing. The sections close to the axis of rotation move slowly and form a large angle with the plane of rotation, while those close to the tip, move faster and form a smaller aerodynamic pitch angle, $\beta(r)$, which varies with the radial distance, r (fig. 2). The geometric pitch, $\lambda(r)$, represents the distance that a propeller would move forward in each revolution. Since the propeller blade has a finite length, it will be subject to both parasitic drag and induced drag and, taking into account that the drag is defined as the component of the aerodynamic force that is parallel to the relative airflow, the total drag on a rotating blade produces a moment about the axis of rotation that opposes the propeller movement [3]. The axis of propeller rotation being aligned closely with the flight direction, this propeller induced moment leads to a rolling moment which must be countered with an aerodynamic moment produced by a command surface.

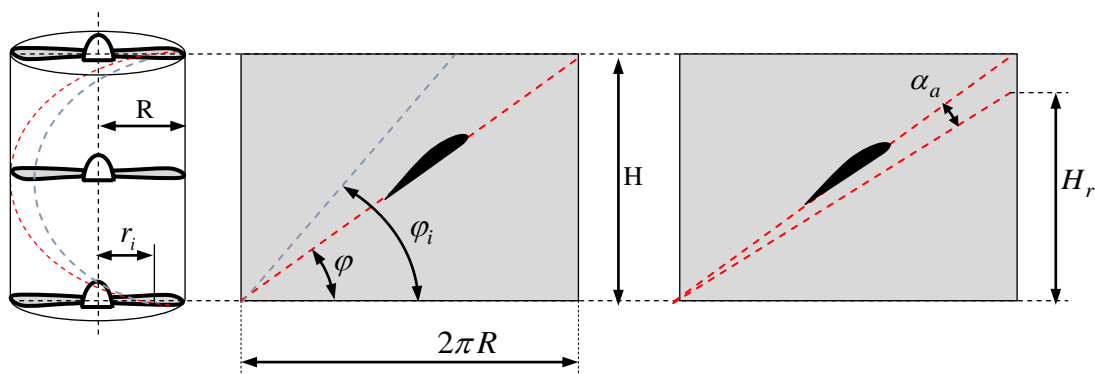

FIG. 2 Propeller theoretical pitch (H) and actual pitch (H_r)

The aerodynamic forces and moments acting on the rotating propeller are also affected by the axial component of the airplane airspeed, because this component of the airspeed is normal to the plane of rotation and it changes the blades angle of attack. This normal component of airflow changes the aerodynamic forces as in the case of finite wing [4].

In the rotation sequence, each blade acts behind the blade that precedes it, so a rotating propeller is equivalent to an infinite series of finite wings, following in a row, one behind the other and the induced velocity is a result so the total downwash generated by all the propeller blades, which are passing repeatedly through the same small section of the flow where the downwash is amplified with each successive pass (fig. 3).

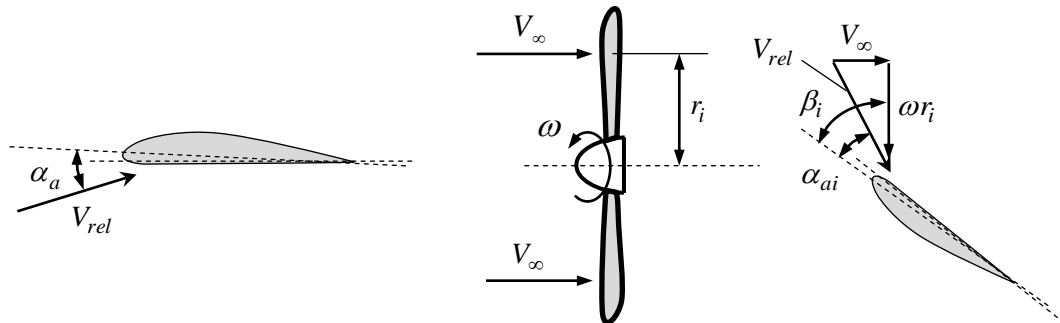

FIG. 3 Propeller velocity triangle

Also, like a wing, the thrust developed by a propeller is a result of the pressure difference between the upstream and downstream of the blade and this pressure difference acting on the air, generates a momentum in a direction opposite to the aerodynamic force acting on the propeller [5]. The engine-propeller combination regarded as a whole, depends on operating conditions and matching the propeller with the engine as well as the matching with the airframe.

2. PROPELLER BLADE THEORY

According to Kutta-Jukovsky theorem, lift force cannot be generated on a rotating propeller blade without the generation of vorticity, that is, for any cross section of a propeller blade, the lift is $L = \rho V_b \Gamma$, where ρ , V_b and Γ are the air density, relative airspeed and circulation. At the blade tip, where the pressure difference between the two sides of the blade cannot be supported, the lift goes to zero and this fact requires that vorticity must be shed from the blade tips of a rotating propeller and also, this shed vorticity produces the induced downwash [6]. The propeller blade tip vortices shed follows a helical path and the region inside the helical trailing vortex system is a region of very strong downwash, which represents the air movement behind a rotating propeller [7].

The velocity induced by each vortex has a component in the circumferential direction because the vortex lines follow a helical path rather than a circular path at any point in space, the resultant induced velocity is the vector sum of the velocity induced by the entire length of all vortex filaments in the slipstream [8]. Computing the velocity induced by the helical vortex system is more complex than for a finite wing and in order to predict this induced velocity we assume that the vortex sheet trailing from a rotating propeller lies along a helical surface of constant pitch and also, this induced velocity is normal to the vector sum of the rotation velocity and forward velocity [9].

3. SOLUTION FOR THE INDUCED ANGLE

From the above considerations to predict the velocity induced in the plane of the propeller disk (fig. 4), the local circumferential component of induced velocity, V_{α} , is related to the local section circulation, Γ , by the equation

$$b\Gamma = 4\pi kfrV_{\theta i} \tag{2}$$

where

$$f = \frac{2}{\pi} \arccos \left\{ \exp \left[-\frac{b \left(1 - \frac{2r}{d_p} \right)}{2 \sin(\beta_t)} \right] \right\} \tag{3}$$

and β_t is the aerodynamic pitch angle at the blade tip.

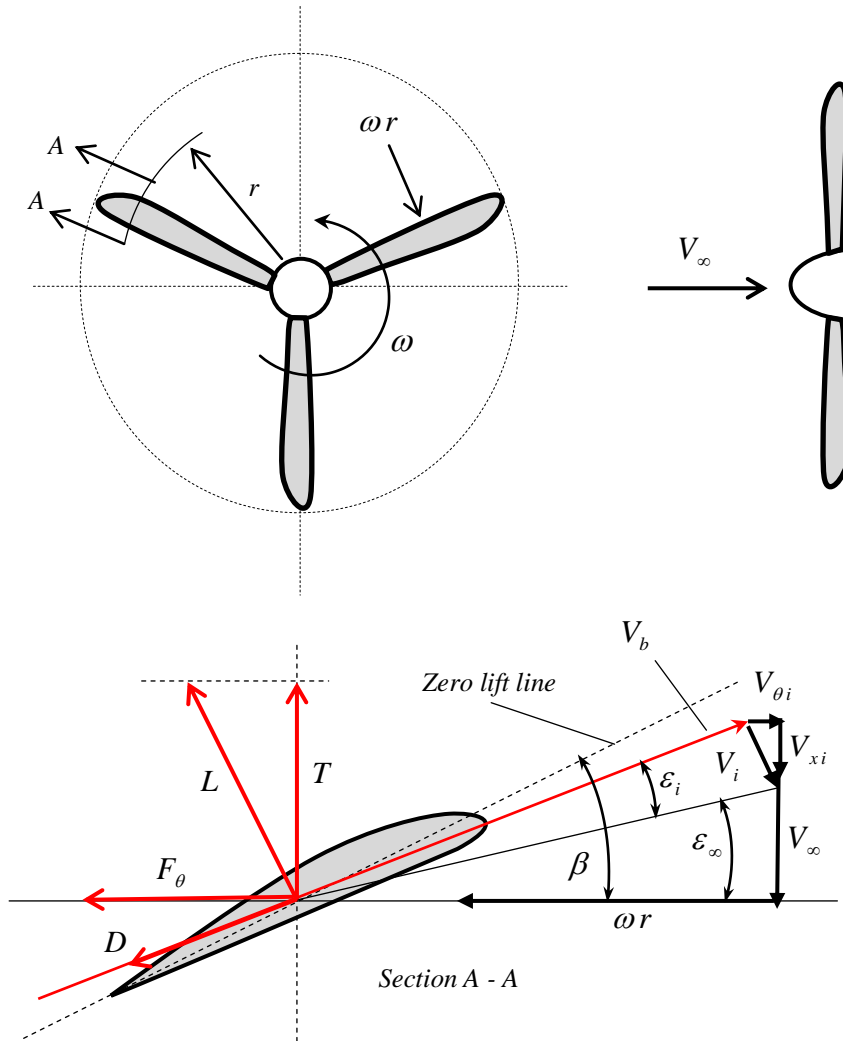

FIG. 4 Forces acting on a propeller blade

The most important component of \vec{V}_b is that given by rotational movement, namely $r\vec{\omega}$. Induced velocity \vec{V}_i has two components, one axial \vec{V}_{xi} and another, circumferential, $\vec{V}_{\theta i}$. Induced velocity is a function of blade radius, where is considered the airfoil. The angles ϵ_b and ϵ_∞ can be determined from velocities triangle according to the following expressions

$$\varepsilon_b(r) = \arctan\left(\frac{V_\infty + V_{xi}}{r\omega - V_{\theta i}}\right) \quad (4)$$

$$\varepsilon_\infty(r) = \arctan\left(\frac{V_\infty}{r\omega}\right) \quad (5)$$

From above equations it follows,

$$\varepsilon_i(r) = \varepsilon_b(r) - \varepsilon_\infty(r) = \arctan\left(\frac{V_\infty + V_{xi}}{r\omega - V_{\theta i}}\right) - \arctan\left(\frac{V_\infty}{r\omega}\right) \quad (6)$$

In order to evaluate the thrust T and the circumferential force F_θ , we must write the mathematical expression of lift and drag for an airfoil with the area of $c_b \cdot 1$ where c_b represents the chord,

$$L = \frac{1}{2} \rho V_b^2 c_b \tilde{C}_l; \quad D = \frac{1}{2} \rho V_b^2 c_b \tilde{C}_d \quad (7)$$

The air relative velocity is

$$V_b^2 = (\omega r - V_{\theta i})^2 + (V_\infty + V_{xi})^2 = \omega^2 r^2 \left[\left(1 - \frac{V_{\theta i}}{\omega r}\right)^2 + \left(\frac{V_\infty}{\omega r} + \frac{V_{xi}}{\omega r}\right)^2 \right] \quad (8)$$

and this expression leads to the following mathematical formulae for thrust, T and circumferential force F_θ

$$T = \frac{1}{2} \rho \omega^2 r^2 c_b \left[\left(1 - \frac{V_{\theta i}}{\omega r}\right)^2 + \left(\frac{V_\infty}{\omega r} + \frac{V_{xi}}{\omega r}\right)^2 \right] [\tilde{C}_l \cos(\varepsilon_b) - \tilde{C}_d \sin(\varepsilon_b)] \quad (9)$$

$$F_\theta = \frac{1}{2} \rho \omega^2 r^2 c_b \left[\left(1 - \frac{V_{\theta i}}{\omega r}\right)^2 + \left(\frac{V_\infty}{\omega r} + \frac{V_{xi}}{\omega r}\right)^2 \right] [\tilde{C}_l \sin(\varepsilon_b) + \tilde{C}_d \cos(\varepsilon_b)] \quad (10)$$

The above equations have as unknowns V_{xi} and $V_{\theta i}$ which can be estimated according to the vortex theory. The numerical theory can give a solution for induced angle, ε_i , then by integration between the blade hub and tip one can get the thrust and the torque moment

$$\frac{bc_b}{16r} \tilde{C}_L - \arccos \left\{ \exp \left[-\frac{b \left(1 - \frac{2r}{d_p}\right)}{2 \sin(\beta_v)} \right] \right\} \tan(\varepsilon_i) \cdot \sin(\varepsilon_i + \varepsilon_\infty) = 0 \quad (11)$$

Taking into account the relative velocity expression

$$V_b = \frac{\omega r}{\cos(\varepsilon_\infty)} \cos(\varepsilon_i) \quad (12)$$

one can get the propeller thrust, T , and torque moment, l , from equations (9) and (10)

$$T = \int_{r_{butuc}}^{r_v} bTdr = \frac{b\rho\omega^2}{2} \int_{r_{butuc}}^{r_v} r^2 \left[\frac{\cos(\varepsilon_i)}{\cos(\varepsilon_\infty)} \right]^2 c_b [\tilde{C}_L \cos(\varepsilon_b) - \tilde{C}_D \sin(\varepsilon_b)] dr \quad (13)$$

$$l = \int_{r_{butuc}}^{r_v} b \cdot r \cdot F_\theta dr = \frac{b\rho\omega^2}{2} \int_{r_{butuc}}^{r_v} r^3 \left[\frac{\cos(\varepsilon_i)}{\cos(\varepsilon_\infty)} \right]^2 c_b [\tilde{C}_L \sin(\varepsilon_b) + \tilde{C}_D \cos(\varepsilon_b)] dr \quad (14)$$

The power required for rotating propeller is $P = l \cdot \omega$

CONCLUSIONS

The dimensionless coefficients of the propeller can be determined knowing the platform shape of the blade and based on the pitch length and propeller diameter variations one can determine the advance ratio and pitch to diameter ratio. The thrust, torque and power coefficients are all functions of the chord length ratio and they depends on the blade cross section. The advanced ratio, $J = 2\pi V_\infty / (\omega d_p)$ depends on operating conditions and flight velocity and for any propeller the thrust and power coefficients decrease with increasing advance ratio. For the angles of attack where the blades are out of stall, the thrust coefficient decreases linear with the advance ratio increase, because the angle of attack is nearly a linear function of advance ratio and for large values of advance ratio the thrust became negative, that means that the propeller is operating as a wind turbine. Very large advance ratio can produce negative angles of attack, therefore there are some particular values for which the thrust developed by a propeller goes to zero and the maximum efficiency is attained for one specific value of advance ratio, so, propellers with low pitch to diameter ratios perform best at low advance ratio.

REFERENCES

- [1] C. E. Moldoveanu, P. Şomoiaş, O. Hemelaar, M. Aubert, *Particularities of the Interaction Between the Aircraft Wake Vortices and the Atmospheric Boundary Layer*, Review of the Air Force Academy, DOI: 10.19062/1842-9238.2015.13.3.6, pp. 95-100, 2015;
- [2] V. Kulish, V. Horak, *Forecasting the Behavior of Fractal Time Series: Hurst Exponent as a Measure of Predictability*, Review of the Air Force Academy, DOI: 10.19062/1842-9238.2016.14.2.8, pp. 61-68, 2016;
- [3] V. Prisacariu, S. Pop, I. Cîrciu, *Recovery System of the Multi-Helicopter UAV*, Review of the Air Force Academy, DOI: 10.19062/1842-9238.2016.14.1.13, pp. 91-98, 2016;
- [4] A. N. Tudosie, *Aircraft Jet Engine Exhaust Nozzle Controller Based on Turbine Pressure Ratio Sensor with Micro-Jet System*, Proceedings of the 11th International Conference on Applied and Theoretical Electricity (ICATE), Craiova, 2012;
- [5] C.E. Moldoveanu, S. Buono, P. Şomoiaş, *Study of the Unguided Rocket Effectiveness*, MTA Review, Vol. XXVI, No. 1, 2016;
- [6] A. N. Tudosie, *Supersonic Air Inlet Control System Based On The Inner Channel Minimum Cross-Section Position Control*, International Conference on Military Technologies ICMT 2009, Brno, Czech Republic, 2009;
- [7] C. Ştefan, *Thunderstorm Occurrence and Associated Flight Hazards in the Southern Part of Romania*, Scientific Research and Education in the Air Force-AFASES 2016, DOI 10.19062/2247-3173.2016.18.1.10, pp. 77-84, 2016;
- [8] C.E. Moldoveanu, A. Giovannini, H. C. Boisson, P. Şomoiaş, *Simulation of Wake Vortex Aircraft in Ground Effect*, INCAS Bulletin, Volume 3, Issue 1/2011, pp. 55-61, ISSN 2066-8201, 2011;
- [9] C. Rotaru, R. I. Edu, *Lift Capability Prediction for Aerodynamic Configurations*, Review of the Air Force Academy, ISSN: 1842-9238, pp. 57-62, 2014.