

STOCHASTIC OPTIMAL CONTROL OF pH NEUTRALISATION PROCESS IN A WATER TREATMENT PLANT

Elena Roxana TUDOROIU, Sorin Mihai RADU, Wilhelm KECS, Nicolae ILIAS
University of Petrosani (tudelena@mail.com)

DOI: 10.19062/1842-9238.2017.15.1.7

Abstract: This paper opens a new research exploration direction in a real time MATLAB/SIMULINK simulation environment to optimize the pH neutralization process level of a generic wastewater treatment plant following a stochastic approach. The control system design of pH neutralization process is a very difficult task to be accomplished due to its severe nonlinearity and complexity characterized by a persistent change in the chemical systems with complex kinetic and thermodynamic reactions, nonlinear responses, a sensitive environment uncertain results and large variety of operating conditions to be covered. Furthermore, the standard control strategies design fail unfortunately when the system performance is concerned. In the new approach the proposed control strategy proved its effectiveness and high accuracy in terms of its performance compare to the traditional control mechanisms. To validate all these results a simplified intuitive nonlinear model of the neutralization reactor from the literature is considered. The solution of the optimization problem is found in a Linear Quadratic Gaussian optimization framework. In this new approach the nonlinear dynamics of the neutralization reactor must be linearized around an equilibrium point, the cost function is quadratic, and the process and measurement noises are white Gaussian noises, independent, of zero mean, and normally distributed. The system's control is Markovian and linear as a combination of observable or estimated states. In addition the implementation of stochastic optimal control approach is more restrictive by introducing a few key concepts and requirements such as controllability, stabilizability, observability, and the certainty-equivalence principle, as well as the well-known separation principle between optimal estimation and optimal control.

Keywords: LQG stochastic control, control system optimization, Linear Quadratic regulator, Linear quadratic estimator, neutralization reactor, MATLAB/SIMULINK

1. INTRODUCTION

The acidity of any solution is assessed by measuring its pH level (e.g. the concentration of positive Hydrogen ions (H^+) in the solution) that ranges in a scale from 1 to 14. The value of 7 for the pH level in any solution at room temperature indicates that the solution is neutral. According to this scale if the pH of the solution at the room temperature is less than 7, the concentration of Hydrogen ions (H^+) in the solution is high, and the solution is considered to be acid [1]. On the other hand if the pH level of the solution at room temperature is greater than 7, the concentration of negative hydroxyl ions (OH^-) in the solution is high and the solution is considered to be alkaline or a base [1]. According to environmental safety standards for industry all treated water effluents must have the pH level of either 8 or 6 [1]. The control system design of pH neutralization process is a very difficult task to be accomplished due to the following reasons [1, 2, 3]:

1) the dynamics of pH neutralization process is severely nonlinear and of high complexity as is shown in Fig. 1(a, b) for a particular case of the titration curve for acid-base process reaction [1].

- 2) a persistent changes in the chemical systems
- 3) complex kinetic and thermodynamic reactions
- 4) nonlinear response of the process,
- 5) a sensitive environment uncertain results
- 6) a large variety of operating conditions to be covered.

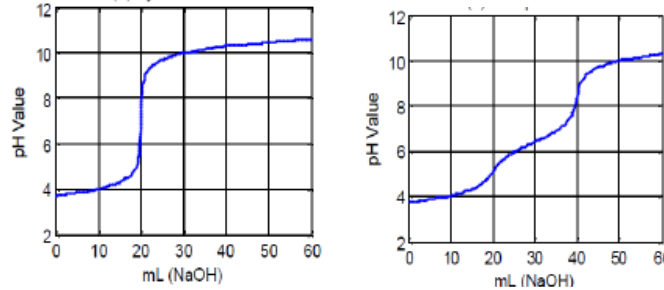

FIG. 1. Titration curve for acid-base process reaction (a snapshot from [1], p.36)
 (a) Hydrochloric acid
 (b) Phosphoric acid

The classical control strategies design fail in the majority of the cases when the system performance is concerned. In the new stochastic approach the proposed optimal control strategy proved its effectiveness and high accuracy in terms of its performance compare to the traditional control mechanisms. To find an optimal solution to this optimization problem a Linear Quadratic Gaussian (LQG) control strategy is proposed. To implement the new LQG strategy the following requirements need to be satisfied [4, 5, 6, 7, 8]:

- (1) the nonlinear dynamics of the neutralization reactor must be linearized around an equilibrium point
- (2) the cost function is quadratic
- (3) the process and measurement noises are white Gaussian, independent, of zero mean, and normally distributed
- (4) the system's control is Markovian and linear as a combination of observable or estimated states.

The optimization problem consists of two distinct parts, that can be easily implemented in MATLAB/SIMULINK framework [4, 5, 6, 7]:

- (a) Linear Quadratic Regulation (LQR) problem
- (b) Linear Quadratic Estimation (LQE) problem

Combining the solutions of the both LQR and LQE problems is a practical real time implementation tool of the LQG control strategy in a feedback closed-loop control system to find the optimal values of the pH level for a neutralization reactor based on a nonlinear intuitive generic model [4, 5, 6, 7, 8].

2. THE NEUTRALIZATION REACTOR DESCRIPTION

In Figure 2 is shown the layout of a simple neutralization reactor used in the chemical industry, where an alkaline input flow (fluent) is neutralized with acid (reagent) in a continuously stirred tank reactor (CSTR) [2]. For this case study the waste water enters the reactor with a federate of $\frac{dV_F}{dt} = \dot{V}_F = 2000[\frac{l}{h}]$ at a $pH_F = 13$ (strongly alkaline); the input acid $\frac{dV_A}{dt} = \dot{V}_A$ and base $\frac{dV_B}{dt} = \dot{V}_B$ flows are dosed and controlled by a PI regulator.

A pH -probe measures pH -actual value of the neutralized solution inside the reactor during the transient and steady state neutralization process, transmitting its feedback to the controller with a lag time of 50 seconds. The reactor volume is assumed to be constant, with a capacity of 4000[l], and the maximum value of the HCl-acid flow with a 25% concentration is $30\frac{l}{h}$. The pH target value is 10 and to simplify the dynamic model only acid addition is considered, due to the fact that the waste water is already alkaline.

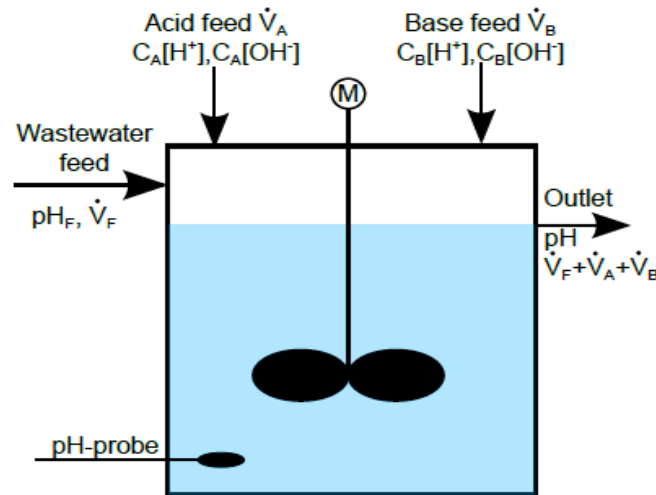

FIG.2. Neutralization CSTR reactor (a snapshot from [2], p.2)

3. FORMULATION OF THE CONTROL OPTIMIZATION PROBLEM

The control optimization problem is formulated based on the well-known optimality principle [4, 5, 6, 7]. According to this principle the optimization problem consists in a sequence of consecutive stages such that “from any point on an optimal trajectory, the remaining trajectory is optimal for the corresponding problem initiated at that point” [4].

The optimality principle is a key concept for defining a control optimization problem (COP) by the following elements given in [4]:

1.”The dynamics of the plant represented in continuous and discrete state-equation (law motion):

$$x_{t+1} = f(x_t, u_t, t) \quad (1)$$

where $t = 0, 1, 2, \dots$ is the discrete-time that takes integer values, $x_t \in \mathfrak{R}^n$ is the value of the control system state vector at time $t \in \mathfrak{T}$, calculable from known quantities and obeys a law motion (1), $u_t \in \mathfrak{R}^m$ is the control system input vector value at time $t \in \mathfrak{T}$, that is chosen on basis of knowing the set of previous controls up to time $t-1 \in \mathfrak{T}$, $U_{t-1} = \{u_{t-1}, u_{t-2}, \dots, u_0\}$.

2. The cost function to be optimized:

$$C = \sum_{t=0}^{s-1} c(x_t, u_t, t) + C_s(x_s) \quad (2)$$

by a suitable choice of the set of controls $U_{s-1} = \{u_{s-1}, u_{s-2}, \dots, u_0\}$

3. An optimal control law attached to the law motion (1) and the cost function (2), known as the optimality equation (dynamic programming equation (DP) or equivalent Bellman equation) to find the optimal value of the control (optimal actuator effort of the control system):

$$F(x_t, t) = \inf_{u_t} [c(x_t, u_t, t) + F(f(x_t, u_t, t), t + 1)], \text{ for } t < s \quad (3)$$

with the terminal condition: $F(x_s, s) = C_s(x_s)$

where the future cost function defined in (2) from time $t \in \mathfrak{T}$ onwards is defined as:

$$C_t = \sum_{\tau=t}^{s-1} c(x_\tau, u_\tau, \tau) + C_s(x_s) \quad (4)$$

with the minimal value calculated as solution of an optimization problem over the sequence of controls $\{u_{s-1}, u_{s-2}, \dots, u_t\}$:

$$F(x_t, t) = \inf_{\{u_{s-1}, u_{s-2}, \dots, u_t\}} [C_t] \quad (5)$$

Furthermore, the DP equation (3) defines an optimal control problem that is related also to a feedback or closed – loop control, defined as:

$$u_t = k(x_t, t), \quad (6)$$

so function only of x_t and t , in contrast to open-loop control system where the sequence of controls $U_s = \{u_{s-1}, u_{s-2}, \dots, u_0\}$ must be calculated all once at time $t = 0 \dots$ [4].

Closing, the DP equation expresses the optimal control solution in close form as in (6) and is also a recursive backward equation in time that gives the optimal control solution $u_{s-1}, u_{s-2}, \dots, u_0$, recursively at the time moments $s-1, s-2, \dots, 0$, governed by a simple rule that the latter control policy is decided first [4]. Let now to consider the stochastic evolution of the neutralization reactor plant by introducing two sequences $X_t = \{x_t, x_{t-1}, \dots, x_0\}$, and $U_t = \{u_t, u_{t-1}, \dots, u_0\}$ that incorporate the history of evolution at time t of plant states and controls, x and u respectively. The evolution of the pH level of neutralization process is described by a state vector denoted by a variable x that takes the value x_t at time t that satisfies the following requirements given in[4]:

1. “...The state vector incorporates a Markov dynamics, i.e. the stochastic version of the dynamics equation of the plant, given by:

$$P(x_{t+1} | X_t, U_t) = P(x_{t+1} | x_t, u_t) \quad (7)$$
2. The COP cost function is decomposable with respect to X_t, U_t , as is shown in (2).
3. The current values of all state vector components x_t are observable, i.e. x_t is known at the time at which the control u_t must be chosen....”

Let us now to designate the observed history of the plant evolution at time t by

$$W_t = (X_t, U_{t-1}), \quad (8)$$

that is related to the cost function C given in (2) at time s [4]:

$$C = C(W_s) \quad (9)$$

Also, the minimal expected cost function from time $t \in \mathfrak{T}$ onwards is defined as in [4]:

$$F(W_t) = \inf_{\pi} E_{\pi}[C_t | W_t] \quad (10)$$

where $E_{\pi}[\cdot]$ is the stochastic expectance operator (stochastic average) of the conditional cost C_t with respect to W_t , and π is a control policy, i.e. a rule to chose the plant control sequence u_{s-1}, \dots, u_0 .

Based on this preparatory elements can be formulated the following remarkable result from the control optimality (see Theorem 1.3 in [4], p. 4):

“...The minimal expected cost $F(W_t)$ is a function of x_t and t alone, let say $F(W_t) = F(x_t, t)$, that obeys the optimality DP equation (3):

$$F(x_t, t) = \inf_{u_t} \{c(x_t, u_t, t) + E[F(x_{t+1}, t+1) | x_t, u_t]\} \text{ for } t < s \quad (11)$$

with the terminal condition

$$F(x_s, s) = C_s(x_s) \quad (12)$$

Moreover, the minimizing value of the control $u_t = k(x_t, t)$ in (11) is optimal....”.

The stochastic approach from this section is useful in the next section to develop a particular case of linear quadratic Gaussian optimization problem.

4. THE LINEAR QUADRATIC REGULATION OPTIMIZATION PROBLEM

In this section the Linear Quadratic Regulation (LQR) optimization problem will be defined, and in the next section LQR will be implemented in a MATLAB/SIMULINK simulation environment to control the pH level of feedback closed-loop control system CSTR chosen as case study.

Using the preliminary theoretical results from previous section the LQR optimization problem will be defined based on the following elements [4]:

(a) The process dynamics linearized in a state-space representation, including the process and measurement noise:

$$\begin{aligned} x_{t+1} &= Ax_t + Bu_t + w_t \\ y_t &= Cx_t + Du_t + v_t \end{aligned} \quad (13)$$

with w_t, v_t the process (w_t) and measurement (v_t) white Gaussian noises (i.e., with normal distribution functions) at time $t \in \mathfrak{T}$ are independent, of zero mean, and with the covariance matrices Q_w , and R_v respectively :

$$E[w_t] = 0, E[v_t] = 0, E[w_t w_t^T] = Q_w, E[v_t v_t^T] = R_v, E[w_t w_s^T] = 0, E[v_t v_s^T] = 0, \text{ for } s \neq t \quad (14)$$

and, also

$$E[w_t v_t^T] = 0, \quad (15)$$

For independent stochastic noise variables, A, B, C, D are matrices of dimensions $n \times n, n \times m, p \times n,$ and $p \times m$ respectively. The variable $y_t \in \mathfrak{R}^p$ from equations (13) represents the measurable plant output.

(b) No all of the n^{th} – components of the state vector $x_t \in \mathfrak{R}^n$ are observable (measurable) at a given time $t \in \mathfrak{T}$

(c) A quadratic optimization criterion given by:

$$J = \sum_{t=0}^{s-1} c(x_t, u_t, t) + J_s(x_s) \quad (16)$$

with one step ahead and a terminal costs [4]:

$$c(x, u) = x^T P_{xx} x + u^T P_{ux} x + x^T P_{xu}^T u + u^T P_{uu} u = \begin{bmatrix} x \\ u \end{bmatrix}^T \begin{bmatrix} P_{xx} & P_{xu}^T \\ P_{ux} & P_{uu} \end{bmatrix} \begin{bmatrix} x \\ u \end{bmatrix}, P_{xu} = P_{ux} = S \quad (17)$$

$$J_s(x) = x \Pi_s x^T \text{ (terminal quadratic cost) }, \Pi_s \in \mathfrak{R}^{n \times n} \quad (18)$$

The quadratic forms P_{xx} , S , P_{uu} in (17) have appropriate dimensions and are non-negative definite (i.e., $x^T P_{xx} x \geq 0$, $u^T S x \geq 0$, $x^T S^T u \geq 0$). In addition, the matrix P_{uu} is assumed to be positive definite (i.e., $u^T P_{uu} u > 0$), and the matrices P_{xx} , P_{uu} , Π_s must be symmetric [4].

This model is suitable for control system regulation for which the state trajectory x is controlled by u such that to end in the point $(0, 0)$ (i.e., steering to a critical value) [4].

Also, the closed form of optimal solution of the COP defined in (13)-(18) is given for free noise but can be adapted to the noise disturbances included in the dynamic model of the plant as is [4], p. 25.

5. KALMAN FILTER – CERTAINTY EQUIVALENCE AND SEPARATION PRINCIPLES

In this section is introduced the famous Kalman Filtering concept concerning the stochastic state estimation, and also two of the most used principles in a stochastic control system optimization will be related to the this concept:

- (a) the certainty equivalence principle
- (b) the separation principle

The Kalman Filter is a powerful and popular tool for the stochastic state estimation that was proposed by R.E. Kalman in 1960. It can be viewed as an important moment in the evolution of control system theory related to that time.

The full Linear Quadratic Gaussian (LQG) model is based on four main assumptions [4]:

(1) *The dynamics of the process is linearized (i.e., represented by stochastic differential equations given in (13))*

$$\begin{aligned} x_{t+1} &= Ax_t + Bu_t + w_t \\ y_t &= Cx_t + Du_t + v_t \end{aligned} \quad (19)$$

(2) *The cost function is quadratic:*

$$c(x, u) = x^T P_{xx} x + 2u^T S x + u^T P_{uu} u \quad (20)$$

(3) *The process and measurement noises are Gaussian (normal distributions, $w_t \propto N(0, Q_w)$, $v_t \propto N(0, R_v)$) with w_t, v_t the process (w_t) and measurement (v_t) white Gaussian noises (i.e., with normal distribution functions) at time $t \in \mathfrak{T}$, of zero mean, independent (uncorrelated), and the covariance matrices Q_w , and R_v respectively :*

$E[w_t] = 0$, $E[v_t] = 0$, $E[w_t w_t^T] = Q_w$, $E[v_t v_t^T] = R_v$, $E[w_t w_s^T] = 0$, $E[v_t v_s^T] = 0$, for $s \neq t$, and $E[w_t v_t^T] = 0$, since stochastic noise variables are independent

(4) *No all the components of the state vector of the control process are observable (measurable).*

A remarkable result related to the Gaussian random variables is provided by Lemma 11.1 together with its proof in [4], p. 41.

This Lemma makes the link between Gaussian nature of the random variables and the stochastic state estimation, well-known in the literature as “*linear least squares estimates*”. According to this Lemma “*if x and y are two Gaussian random variables jointly normal distributed with zero mean and the covariance matrix:*

$$E\left(\begin{bmatrix} x \\ y \end{bmatrix} \begin{bmatrix} x & y \end{bmatrix}\right) = \text{cov}\left(\begin{bmatrix} x \\ y \end{bmatrix}\right) = \begin{bmatrix} V_{xx} & V_{xy} \\ V_{yx} & V_{yy} \end{bmatrix} \quad (21)$$

then the distribution of x conditional on y is also Gaussian, with:

$$E(x|y) = V_{xx}V_{yy}^{-1}y \quad (\text{conditional mean}), \text{ and} \quad (22)$$

$$\text{cov}(x|y) = V_{xx} - V_{xy}V_{yy}^{-1}V_{yx} \quad (\text{conditional covariance}) \quad (23)$$

The linear least square estimate of x in terms of y (also, known for Gaussian case as the maximum likelihood estimator) is defined as [4]:

$$\hat{x} = Hy = \hat{P}_{xy}\hat{P}_{yy}^{-1}y, \text{ with } H = \hat{P}_{xy}\hat{P}_{yy}^{-1} \dots"$$

Remark: Even without the assumption that x and y are jointly normal distributed, this linear function of y has a smaller covariance matrix than any other unbiased estimate for x that is a linear function of y [4].

Closing, the control system state trajectory starts from the initial state x_0 distributed conditional on W_0 as normal Gaussian, $x_0 \propto N(\hat{x}_0, \hat{P}_{xx,0})$, and obeys together with the observable plant outputs to the recursions of the full LQG model given in a discrete state-space stochastic equations (19). Then conditional on W_t , the actual current state is Gaussian normal distributed $x_t \propto N(\hat{x}_t, \hat{P}_{xx,t})$. The conditional mean and variance obey the following updating recursions [4] (see Theorem 11.2, p.42):

$$\hat{x}_t = A\hat{x}_{t-1} + Bu_{t-1} + K_t(y_t - C\hat{x}_{t-1}) \quad (24)$$

$$P_{xx,t} = Q_w + AP_{xx,t-1}A^T - (L_{ww} + AP_{xx,t-1}C^T)(R_v + CP_{xx,t-1}C^T)^{-1}(L_{ww}^T + CP_{xx,t-1}A^T) \quad (25)$$

and the Kalman matrix gain K_t is given by:

$$K_t = (L_{ww} + AP_{xx,t-1}C^T)(R_v + CP_{xx,t-1}C^T)^{-1} \quad (26)$$

The equations (24)-(26) are developed based on the following assumption:

$$\text{cov}\begin{pmatrix} w_t \\ v_t \end{pmatrix} = E\left\{\begin{pmatrix} w_t \\ v_t \end{pmatrix}\begin{pmatrix} w_t & v_t \end{pmatrix}\right\} = \begin{bmatrix} Q_w & L_{ww} \\ L_{ww}^T & R_v \end{bmatrix} \quad (27)$$

and, also taking into account that at the moment $t-1$ when the plant control u_{t-1} becomes known but the plant output observation y_t is not available (known) yet the distribution (x_t, y_t) conditional on (W_{t-1}, u_{t-1}) is jointly normal with the means:

$$E(x_t | W_{t-1}, u_{t-1}) = A\hat{x}_{t-1} + Bu_{t-1} \quad (\text{Markov stochastic process also}) \quad (28)$$

$$E(y_t | W_{t-1}, u_{t-1}) = C\hat{x}_{t-1} \quad (29)$$

For the independent sequences of noises (w_t, v_t) the matrix covariance becomes more

simple $\text{cov}\begin{pmatrix} w_t \\ v_t \end{pmatrix} = \begin{bmatrix} Q_w & 0 \\ 0 & R_v \end{bmatrix}$, a diagonal matrix that simplify also the equations (24)-(26),

very useful for algorithm implementation in practice.

The main idea of equivalent uncertainty principle is that "the optimal control u_t is exactly the same as it would be if all unknowns were known and took values equal to their linear least square estimates (equivalently, their conditional means) based upon observations up to time t " [4].

Finally, the following two main issues concerning the state estimation and optimal control must be considered:

(1) The state estimate \hat{x}_t can be calculated recursively from the Kalman Filter stochastic equation (24):

$$\hat{x}_t = A\hat{x}_{t-1} + Bu_{t-1} + L(y_t - C\hat{x}_{t-1})$$

that contains two main terms: $A\hat{x}_{t-1} + Bu_{t-1}$, and $L(y_t - C\hat{x}_{t-1})$ that seems to reproduce the noise contaminated plant dynamics, L representing the estimated observer gain:

$$x_{t+1} = Ax_t + Bu_t + w_t$$

where the process noise w_t is given now by an innovation stochastic process:

$$\tilde{w}_t = \tilde{y}_t = y_t - C\hat{x}_{t-1} \quad (30)$$

that can be viewed as a *colored noise* rather than a *white noise*.

(2) If the controlled plant is complete observable in terms of the components of the plant state vector, i.e., $y_t = x_t$, the optimal plant control is given by:

$$u_t = K_t x_t, \text{ as linear combination of the plant states,} \quad (31)$$

then if the controlled plant is partially observable the optimal plant control is given by:

$$u_t = K_t \hat{x}_t, \quad (32)$$

as a linear combination of the best linear least squares state estimates of x_t based on the available input-output measurements (observations) (Y_t, U_{t-1}) at time t .

A remarkable result can be obtained by evaluating the residual of the state:

$$\begin{aligned} \varepsilon_t &= \hat{x}_t - x_t = A\hat{x}_{t-1} + Bu_{t-1} + L(y_t - C\hat{x}_{t-1}) - x_t = \dots \\ &= (A - LC)\hat{x}_{t-1} + Bu_{t-1} + LCx_t - Ax_{t-1} - Bu_{t-1} = (A - LC)\hat{x}_{t-1} + LCx_t - Ax_{t-1}, \end{aligned} \quad (33)$$

The residual of the state given by (39) does not depend on the sequence of the past history of plant controls U_{t-1} . This result is very important to decouple the optimal control from optimal estimation, well known in the control systems literature as *separation principle* [4, 5, 6, 7, 8] corresponding to a control system structure shown in Fig. 3. This structure it is also easy to be implemented in real time MATLAB/SIMULINK simulation environment.

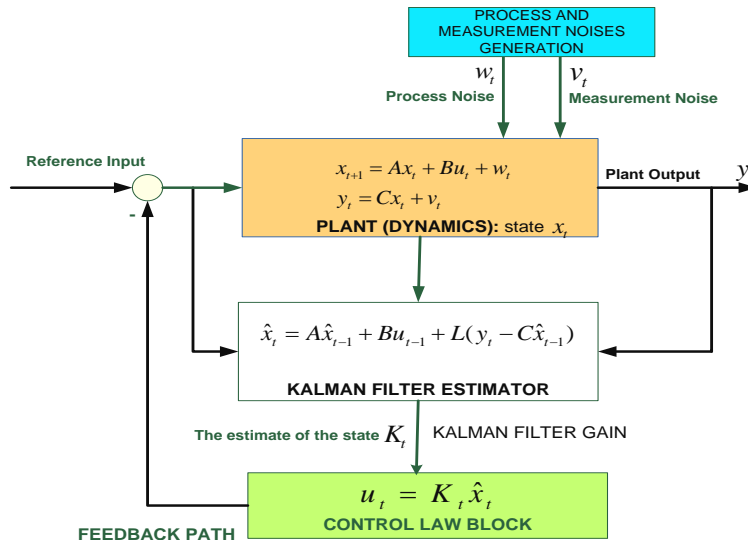

FIG. 3. Separation Principle Control System Structure

A consequence of the separation principle is that the observer and controller can be designed separately—the controller gain K can be computed independently of the estimated Kalman observer gain, L , with two decoupled dynamics: the control plant dynamics controlled by the dynamics of the observer estimator through its optimal gain as is shown in Fig. 4, and from SIMULINK model in Fig.10.:

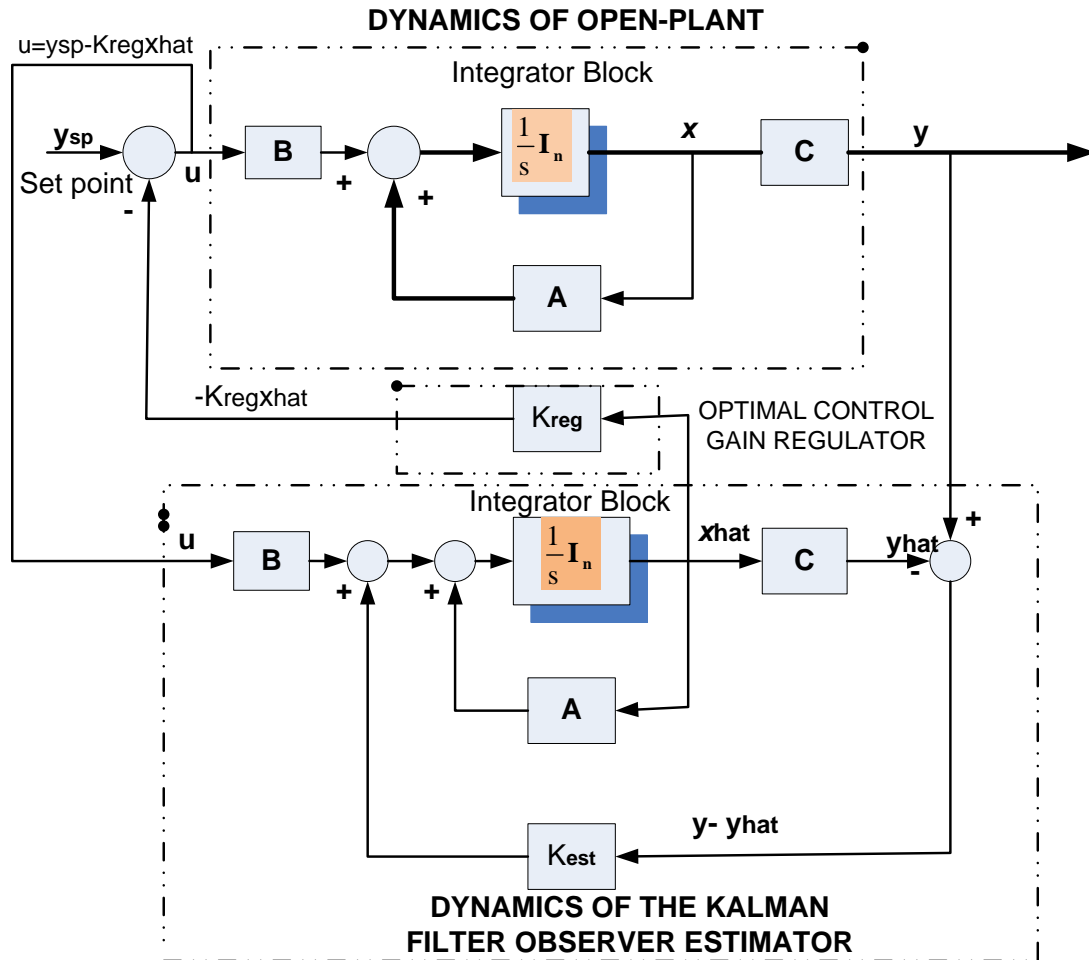

FIG. 4. Detailed Decouple Dynamics of Control System Structure

6. THE CASE STUDY – NEUTRALIZATION REACTOR INTUITIVE GENERIC MODEL

The dynamic and steady state simulation model for pH neutralization process consists of a system of equations based on mass and charge balances on the continuous stirred tank reactor (CSTR). An intuitive simple and complete generic dynamic model of CSTR in a state-space representation is developed in [2], very useful to implement the proposed optimal control system strategy and to evaluate its effectiveness in a stochastic approach. In the document paper [2] the modeling part is quite fast implemented and validated in SIMULINK environment, but it is quite difficult to propose a stable feedback control closed-loop for this highly non-linear system [2]. The following two crucial issues in developing a pH neutralization reactor dynamic model which describes the nonlinearity of the neutralization process have emerged from published literature research [2]:

(1) The positive hydrogen ion (H^+) or negative hydroxyl ion concentrations (OH^-) from material balances equations is extremely difficult to record, due to the fact that the dissociation of water and resultant (effluent) slight change in water concentration must be accounted.

(2) Instead, the material balances equations are performed on all other atomic species and all supplementary equilibrium interactions are used in addition with the electro-neutrality principle of the positive and negative ion concentrations to simplify the equations.

The dynamic model of the neutralization process is developed based on the component material balance and the equilibrium equations under the following assumptions [2, 3]:

- (a) The acid-base reactions inside the CSTR system are ionic and take place at a constant reaction rates.
- (b) The CSTR system is ideal without any pollutant influence.
- (c) Linear mixing volume (i.e., no miscibility gap) of acid and waste water.
- (d) The valve dynamics are much faster compared to the neutralization process dynamics, therefore is neglected.
- (e) The pH sensor dynamics is represented by a first order lag element with a delay time of 50 seconds.
- (f) The volume V of the tank is constant.

The basic intuitive model developed in [2] is suitable for this case study since it is very simple and captures with enough precision the sharp nonlinear characteristics of a single acid-single base continuous stirred tank reactor (CSTR) neutralization process.

6.1 The nonlinear dynamics of CSTR – The nonlinear intuitive model

The nonlinear dynamics of the CSTR neutralization process shown in Fig. 2 is described in [2] by following first-order state-space differential equation:

$$\frac{dx(t)}{dt} = -\frac{\dot{V}_F}{V}x(t) + \left(-\frac{1}{V}x(t) + \frac{b_A}{V}\right)u_1(t) + \frac{\dot{V}_F b_F}{V} = f(x(t), u_1(t), u_2(t)) \quad (34)$$

$$y(t) = -\log_{10}[0.5(x(t) + \sqrt{(x(t))^2 + 4 \times 10^{-14}})] = g(x(t)) \quad (35)$$

where:

- the process state $x(t) = C[H^+] - C[OH^-] \left[\frac{mol}{l} \right]$ (the difference between the positive ions

concentration $C[H^+]$ and negative ions concentration $C[OH^-]$)

- \dot{V}_F is the waste water feed flow $\left[\frac{l}{h} \right]$

- the neutralization process inputs $u_1(t) = \dot{V}_A$ (HCl -acid flow) and $u_2(t) = \frac{\dot{V}_F b_F}{V}$ as a new constant step input (disturbance).

- $b_F = C_F[H^+] - C_F[OH^-]$ (the difference between the positive ions concentration $C_F[H^+]$ and negative ions concentration $C_F[OH^-]$ in the waste water feed flow \dot{V}_F)

- $b_A = C_A[H^+] - C_A[OH^-]$ (the difference between the positive ions concentration $C_A[H^+]$ and negative ions concentration $C_A[OH^-]$ in the HCl -acid flow \dot{V}_A)

- the neutralization process output $y(t) = pH$

- f, g are two nonlinear functions used to describe in a compact form the nonlinear dynamics of the neutralization process and of the observable process output respectively.

- V is the constant volume of the CSTR $[l]$

6.2 The linearized dynamics of CSTR – The linear intuitive model

A standard linearized version of the intuitive CSTR model can be obtained by linearizing the nonlinear functions f and g around an operating point (i.e., an equilibrium point obtained in steady state, when), keeping only the linear terms from a Taylor series development. In state-space representation standard form the intuitive linear model of CSTR neutralization process is the same with those developed in scalar form as in [2].

$$\frac{dx(t)}{dt} = Ax(t) + Bu(t) \quad (36)$$

$$y(t) = Cx(t) \quad (37)$$

with the Jacobean matrices (scalars) given by:

$$A = \left(\frac{\partial f}{\partial x} \right) (x_e, u_e) = -\frac{\dot{V}_F + u_e}{V}, B = \left(\frac{\partial f}{\partial u} \right) (x_e, u_e) = \frac{b_A - x_e}{V}$$

$$C = \left(\frac{\partial g}{\partial x} \right) (x_e, u_e) = -\frac{1}{\ln(10)} \frac{1}{\sqrt{x_e^2 + 4 \times 10^{-14}}} \quad (38)$$

$$x_e \cong -10^{-4}, u_e = -\dot{V}_F \frac{10^{-4} + b_F}{b_A + 10^{-4}} = \dot{V}_F \frac{x_e - b_F}{b_A + x_e}$$

In the linear standard state-space representation the free term from the nonlinear intuitive CSTR model $u_2(t) = \frac{\dot{V}_F b_F}{V}$ is removed and can be viewed as a constant disturbance (i.e., a new step input).

6.3 The nonlinear CSTR Reactor step response – Simulation results

The step response simulation results for the nonlinear and linearized CSTR intuitive models are shown in Fig.5 to Fig.8 with the following process parameters values set to the same values as those given in [2]:

- the feed rate of the waste water $\dot{V}_F = 3000 \left[\frac{l}{h} \right]$,
- the pH in the waste water feed rate is $pH_F = 13$,
- the concentration of the H^+ positive ions in the waste water is $C_F[H^+] = 10^{-pH_F} = 10^{-13}$,
- the concentration of the OH^- negative ions is $C[OH^-] = 10^{\frac{-14}{C_F[H^+]}} = 10^{-1}$,
- $b_F = (C[H^+] - C[OH^-]) \left[\frac{mol}{l} \right] = 10^{-13} - 10^{-1} \cong -0.1 \left[\frac{mol}{l} \right]$,
- maximum feed rate of the HCl -acid pump is $Q_{acid_pump} = 45 \left[\frac{l}{h} \right]$
- HCl -acid mass concentration is $C_{A,m} = 25\%$,
- HCl -acid mol weight is $C_{A,wt} = 36.46 \left[\frac{g}{mol} \right]$,
- HCl -acid density is $C_{A,\rho} = \frac{(37 - C_{A,m})}{37} \times 1000 + \frac{C_{A,m}}{37} \times 1190 = 1.1284 \text{ [g/l]}$
- the concentration of the H^+ positive ions in the HCl -acid is $C_A[H^+] = C_{A,m} / 100 \times C_{A,\rho} / C_{A,wt} = 7.7371 \left[\frac{mol}{l} \right]$,

- the concentration of the OH^- negative ions in the HCl -acid is

$$C_A[OH^-] = 10^{\frac{-14}{C_A[H^+]}} = 10^{\frac{-8}{6.1171}} \cong 1.2925e-15 \left[\frac{mol}{l} \right]$$
- $$b_A = (C_A[H^+] - C_A[OH^-]) \left[\frac{mol}{l} \right] \cong 7.7371 \left[\frac{mol}{l} \right]$$
- the volume of CSTR $V=3000[l]$,
- the initial value of pH is $pH_0 = pH_F = 13$,
- the initial value of the concentration of the positive ions H^+ of the solution inside the reactor is $C_{CSTR,0}[H^+] = 10^{-pH_0} = 10^{-13} \left[\frac{mol}{l} \right]$,
- the initial value of the concentration of the negative ions OH^- of the solution inside the reactor is $C_{CSTR,0}[OH^-] = 10^{(pH_0-14)} = 10^{-1} \left[\frac{mol}{l} \right]$,
- $b_{CSTR,0} = (C_{CSTR,0}[H^+] - C_{CSTR,0}[OH^-]) \left[\frac{mol}{l} \right] \cong -0.1 \left[\frac{mol}{l} \right]$
- the set point value of the pH for linearized intuitive model is $pH_{sp} = 11$,
- the plant output equilibrium point is $y_e = pH_{sp} = 11$,
- the steady-state equilibrium point is $x_e = 10^{-pH_{sp}} - 10^{(pH_{sp}-14)} = 10^{-11} - 10^{-1} \cong -0.1$,
- and $u_e = \frac{V_F(x_e - b_F)}{b_A - x_e} = \frac{3000(-0.1 + 0.1)}{-0.0492 + 0.1} \cong 0$,
- initial value of CSTR state is $x_0 = b_F \cong -0.1$, so closed enough to the equilibrium point.

In Figure 5 is shown the step response of the open-loop nonlinear intuitive model that behaves as the titration nonlinear curve of the dynamics of the neutralization process. This step response correspond to a maximum step value of the HCl acid flow variation shown in Fig. 6. (i.e., 45 l/h HCl).

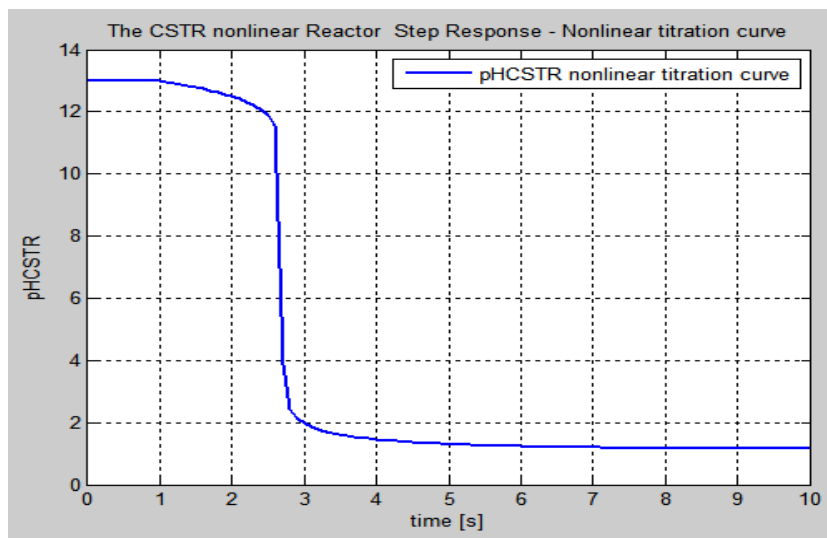

FIG. 5. The nonlinear titration curve of CSTR neutralization reactor – Step response

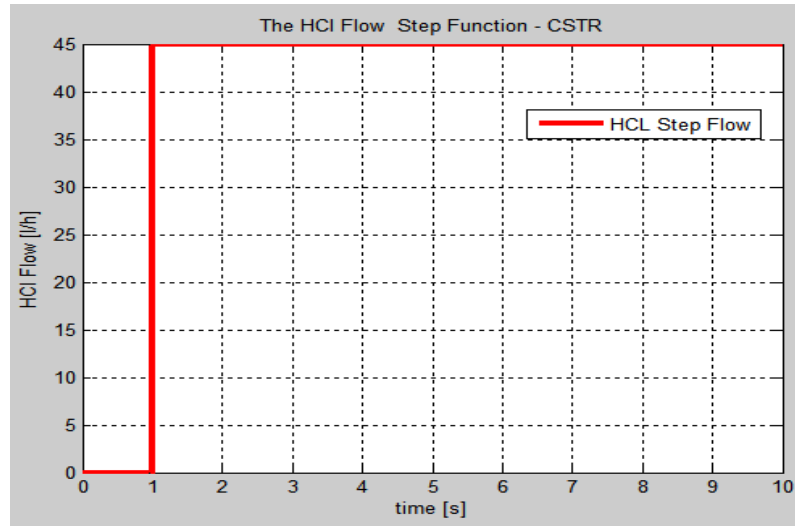

FIG. 6. The HCl CSTR Flow step function

For the linearized CSTR dynamics of the neutralization process similar results are shown in Fig. 7 to a HCl step flow shown in Fig. 8.

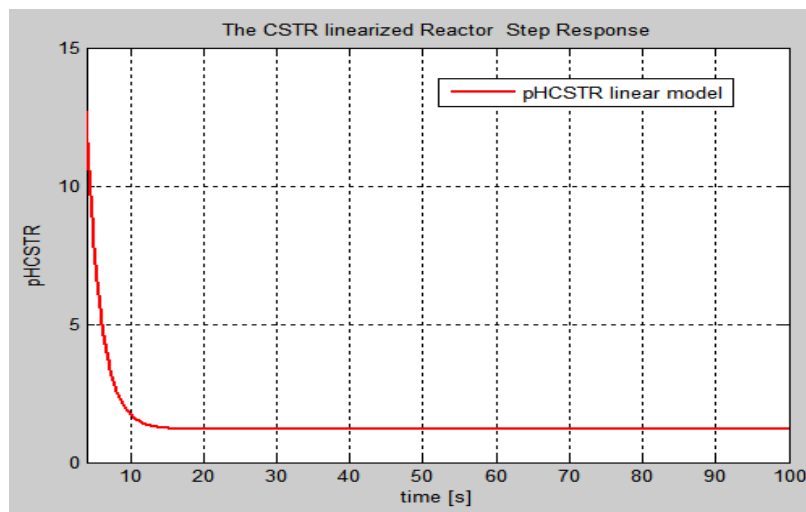

FIG. 7. The step response of linear CSTR neutralization reactor

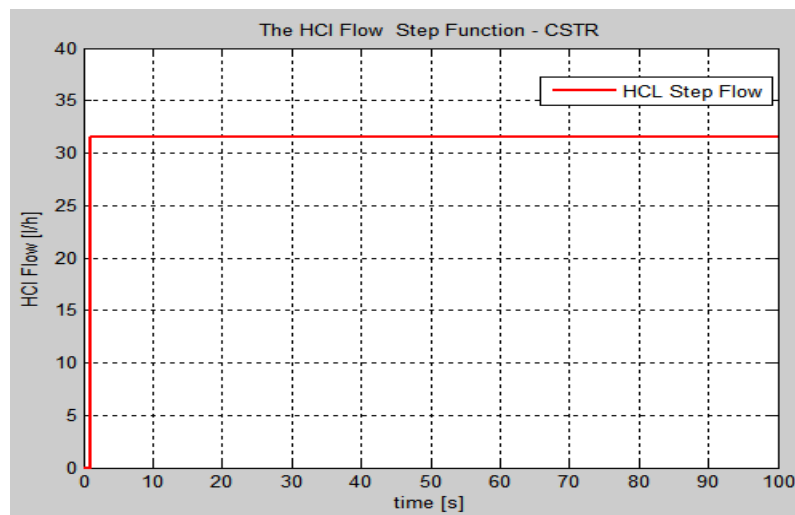

FIG. 8. The HCl of linear CSTR Flow step function

In Fig. 9 is shown the SIMULINK model of intuitive CSTR nonlinear model, similar to those presented in [2], used as experiment set up to determine the nonlinear titration curve. Of the neutralization process, as is shown in Fig.5.

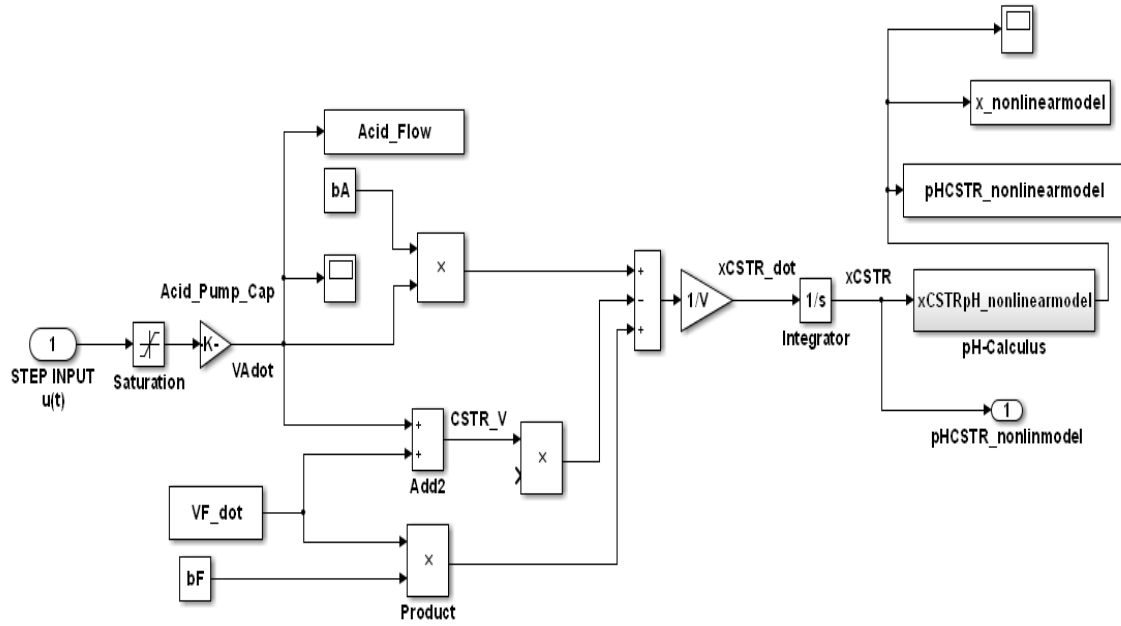

FIG. 9. The SIMULINK model of intuitive CSTR nonlinear model

7. IMPLEMENTATION IN REAL TIME OF LQR CONTROL STRUCTURE IN MATLAB/SIMULINK – SIMULATION RESULTS

According to the development from section 4 and based on the optimal control structure shown in Fig. 3, the complete LQG model is well defined by the following elements:

1. The discrete time linearized process dynamics of the intuitive CSTR model in state-space representation obtained from (42) – (43) by replacing the derivative of the state using the Euler approximation:

$$\frac{dx(t)}{dt} = \frac{x_{t+1} - x_t}{T_s}, \quad (39)$$

where T_s is the sampling time [s], $t = kT, k = 0, 1, 2, \dots, N$ - the discrete-time moments

$$x_{t+1} = (1 + A \times T_s)x_t + T_s B u_t + w_t \quad (40)$$

$$y_t = C x_t + v_t$$

$$\text{cov} \begin{pmatrix} w_t \\ v_t \end{pmatrix} = E \left\{ \begin{pmatrix} w_t \\ v_t \end{pmatrix} \begin{pmatrix} w_t & v_t \end{pmatrix} \right\} = \begin{bmatrix} Q_w & 0 \\ 0 & R_v \end{bmatrix}, \quad w_t, v_t \text{ -white Gaussian process and}$$

measurement noises, zero mean and independent, with the covariance matrices Q_w and R_v respectively.

2. Quadratic optimization criterion:

$$J_0 = \min_u E \left(\sum_{t=0}^{s-1} x^T P_{xx} x + 2u^T S x + u^T P_{uu} u \right) + J_s(x_s), \quad (41)$$

3. The recursive stochastic Kalman Filter state estimate equation:

$$\hat{x}_t = A \hat{x}_{t-1} + B u_{t-1} + K_t (y_t - C \hat{x}_{t-1}) \quad (42)$$

4. The optimal value of the plant control:

$$u_t = K_t \hat{x}_t \tag{43}$$

The scalars A, B, C from description (42)-(43) of the intuitive linearized CSTR model are given in the section 7.3. The combined decoupled LQG SIMULINK control structure in LQR and LQE for linearized CSTR dynamics is shown in Fig. 10. To eliminate the steady-state error between the pH input set point and the output pH actual level in the LQG structure it will be also integrated a PI controller. In the unit feedback path between the pH sensor and the comparator it will be integrated a Transport delay block, with a time delay of 50 seconds. The subsystems of full control structure are shown as SIMULINK blocks in Fig. 11 to Fig. 13.

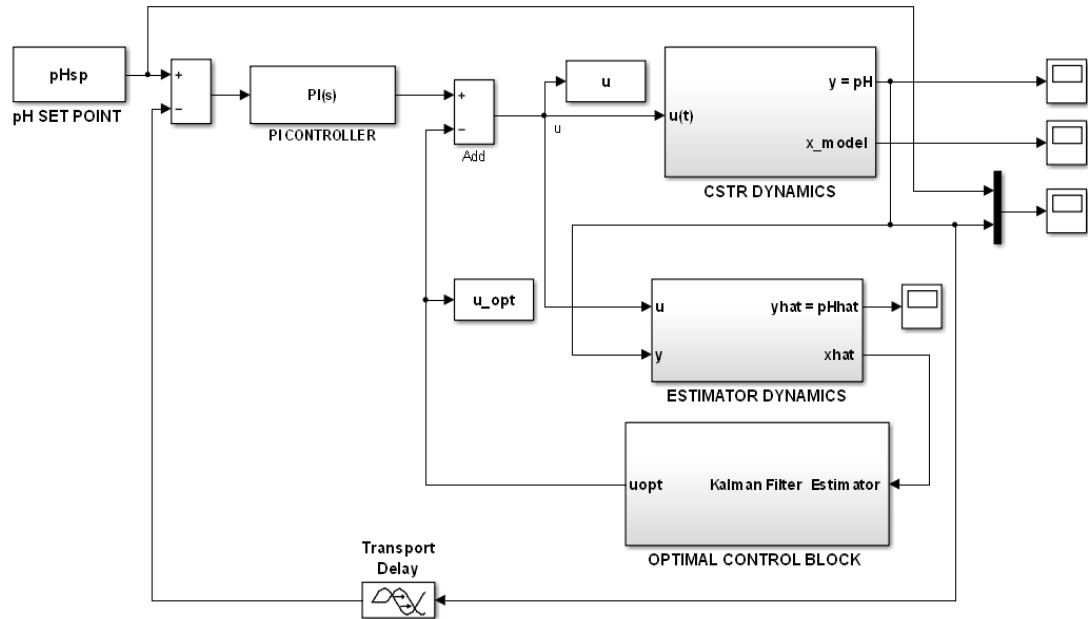

FIG. 10. The SIMULINK model of the decoupled combination LQR and LQE of the intuitive CSTR nonlinear model

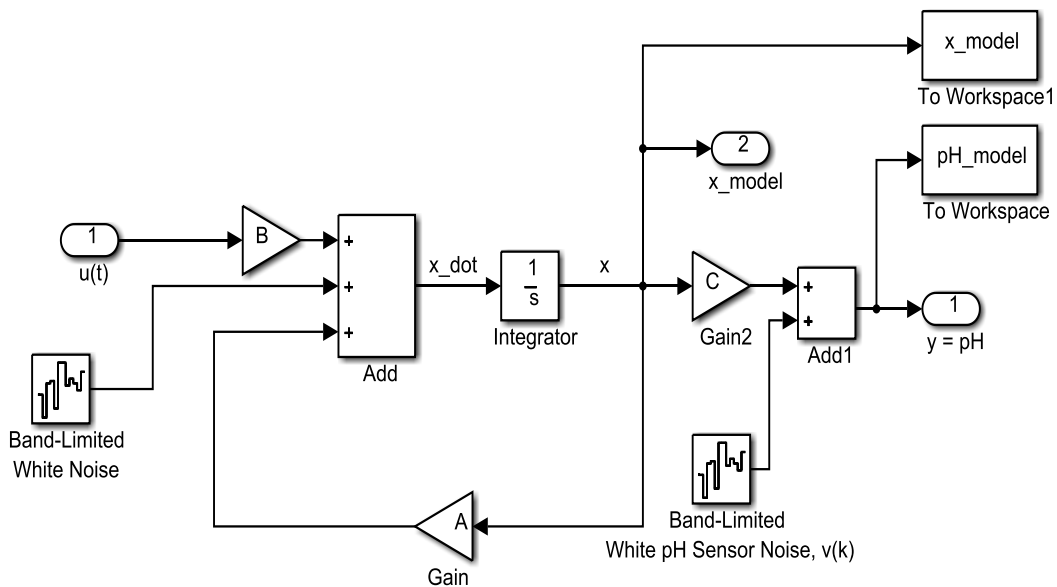

FIG. 11. The SIMULINK model of linear dynamics of LQR CSTR control system

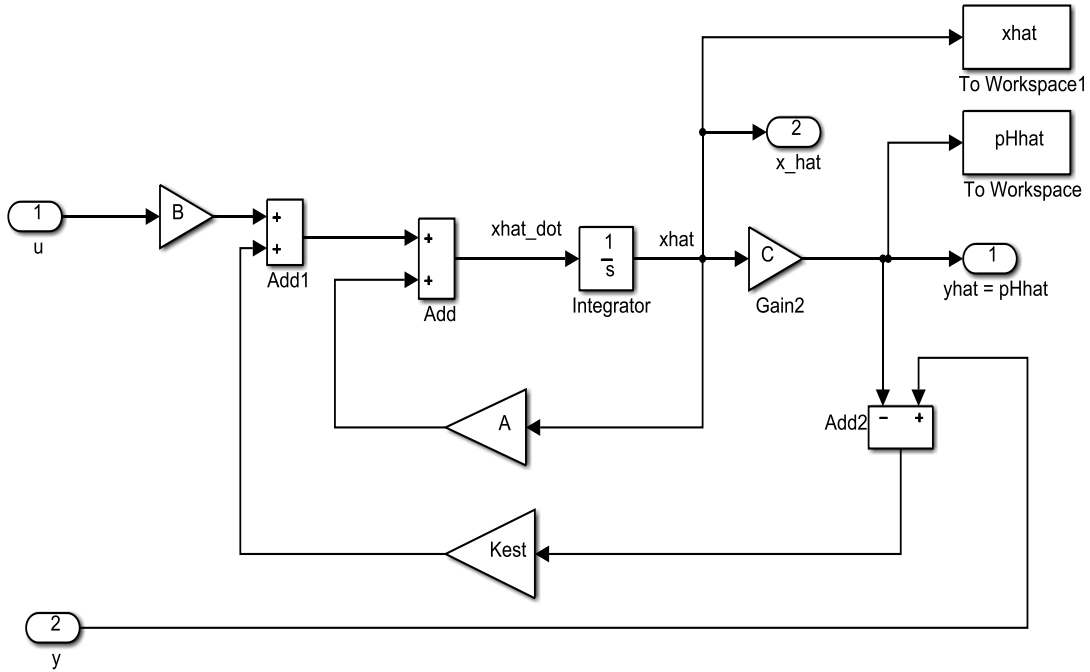

FIG. 12. The SIMULINK model of linear dynamics of LQE CSTR control system

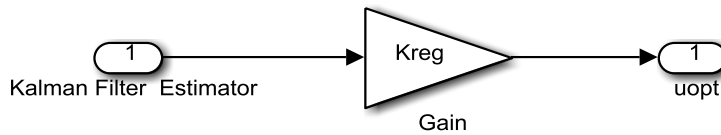

FIG. 13. The SIMULINK model of the optimal control block of the LQG control system

Starting with a pH13 as initial level of the CSTR pH and choosing as a set point of pH level as pH11 in a combined control structure LQG with a PI controller tuned for an integration time coefficient to $K_i = -0.3936$ and proportionality coefficient to $K_p = -9.7736$ the simulation results are shown in Fig. 14 to Fig. 17. To eliminate the variations of high frequency in the useful signal a Moving Average Filter (MAV) it will be used. The windows lengths for MAV are set randomly to 50, and 100 respectively

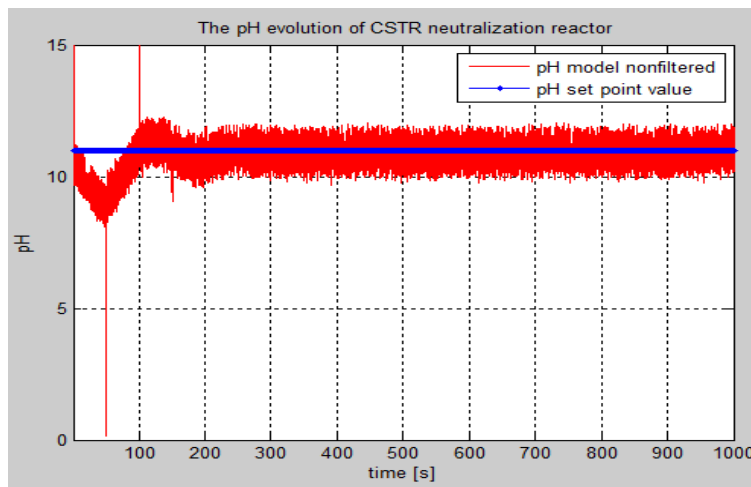

FIG. 14. The control of pH value for the linearized CSTR neutralization plant from pH13 to pH11 using LQG control combined with PI controller (no filtered)

The filtered pH waste water level and the states are shown in Fig. 15 to Fig.16, and in Fig. 17 it shown the actuator effort to keep this pH level to pH11.

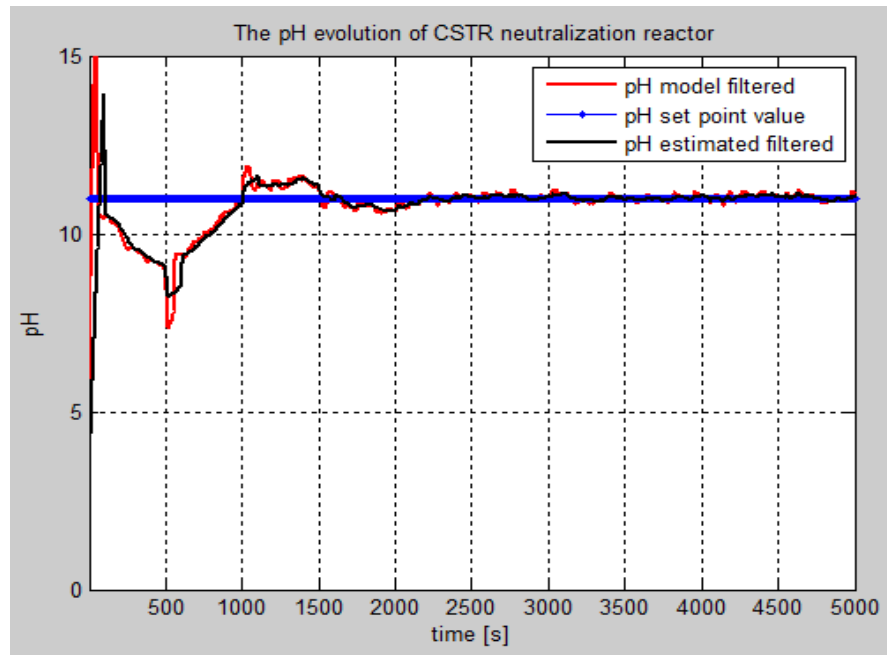

FIG. 15. The control of pH value for the linearized CSTR neutralization plant from pH13 to pH11 using LQG control combined with PI controller (filtered by using a Moving Average Filter)

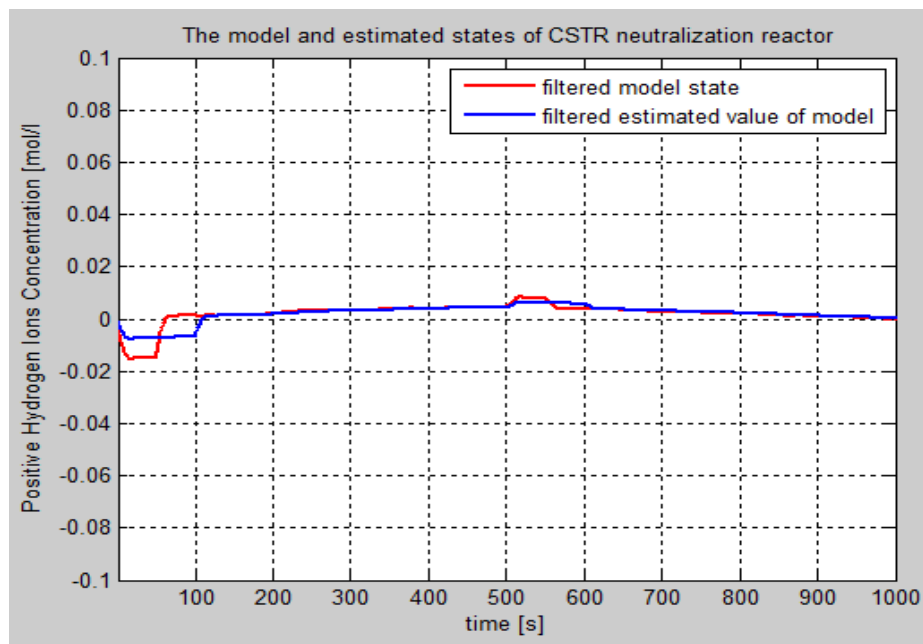

FIG. 16. The filtered model and estimated states for the linearized CSTR neutralization plant from pH13 to pH11 using LQG control combined with PI controller (filtered by using a Moving Average Filter)

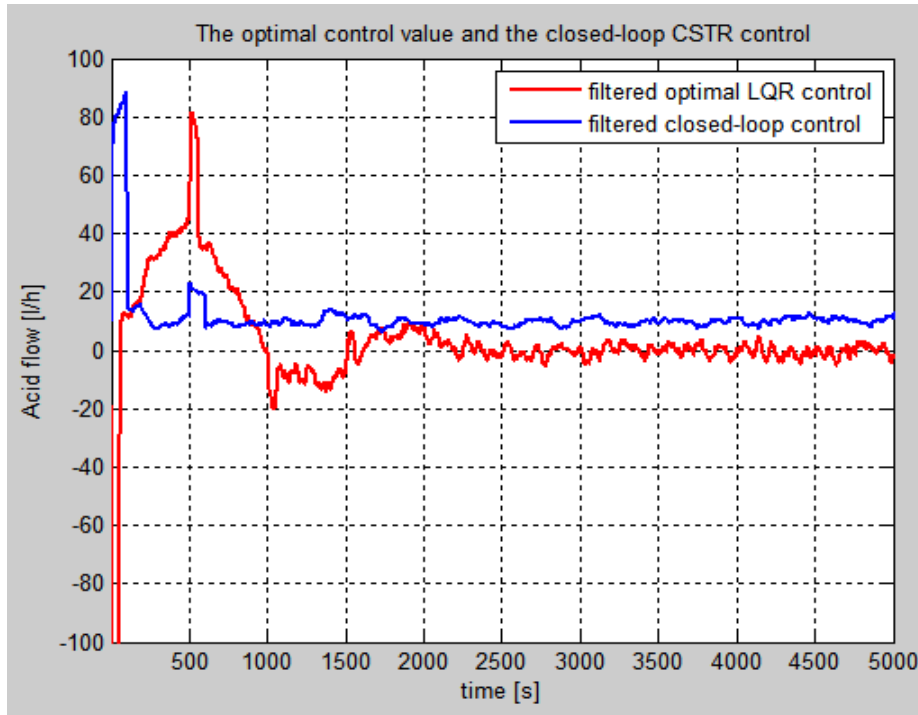

FIG. 17. The filtered optimal LQR control for the linearized CSTR neutralization plant from pH13 to pH11 using LQG control combined with PI controller (filtered by using a Moving Average Filter)

For a new set point of pH level starting the neutralization process from pH13 to pH10.5, using a combined control structure LQG with an I controller having the integration time coefficient set to $K_i = -0.0229$ the simulation results are shown in Fig. 18 and Fig. 19. The windows lengths for Moving Average Filter at this time are set to 500, 250 respectively.

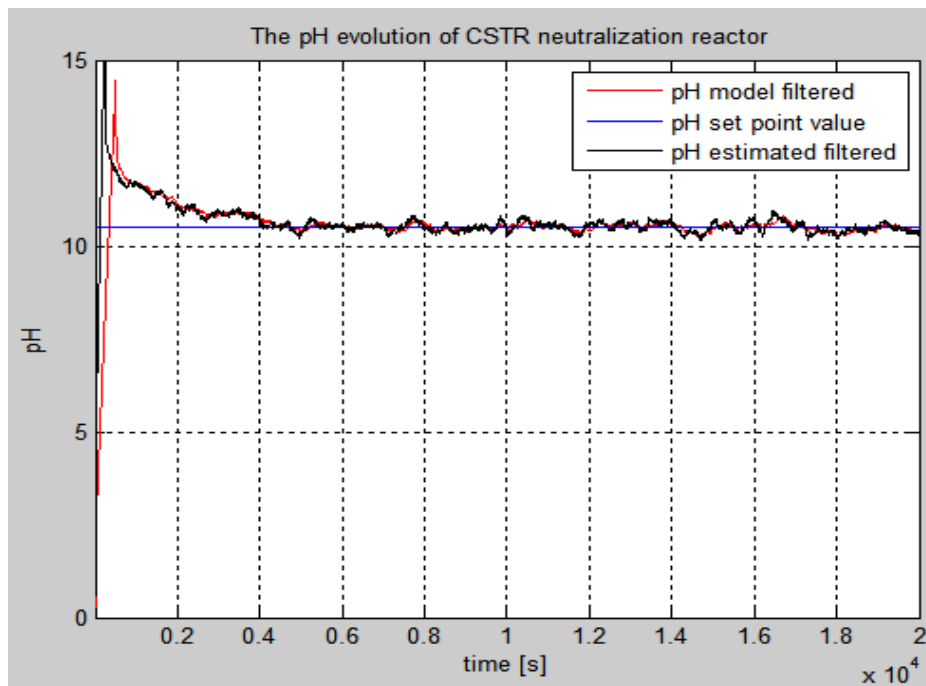

FIG. 18 The control of pH value for the linearized CSTR neutralization plant from pH13 to pH10.5 using LQG control combined with an I controller (filtered by using a Moving Average Filter)

In figure 18 it is easy to see the good accuracy of the controlled level of the CSTR pH neutralization plant from pH13 to pH10.5 with a controller effort shown in Fig.19. After almost 600 seconds the optimal effort of the LQR controller becomes very small.

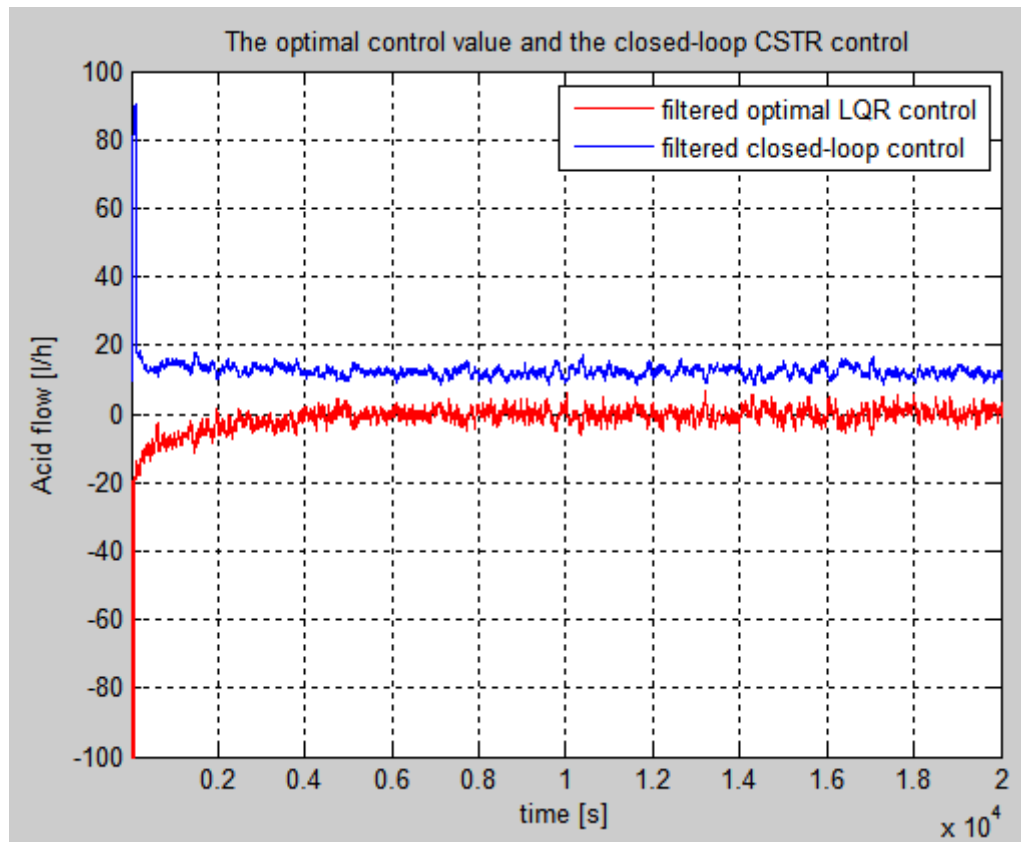

FIG. 19. The filtered optimal LQR control for the linearized CSTR neutralization plant from pH13 to pH10.5 using LQG control combined with an I controller (filtered by using a Moving Average Filter)

CONCLUSIONS

In this research paper is developed a stochastic LQG approach to solve a particular optimization problem, such as the optimal control of pH level of the waste water CSTR neutralization plant. The control system design of pH neutralization process is a very difficult task to be accomplished since the model of CSTR neutralization plant is highly nonlinear (see the titration curve), and also it is very complex. Furthermore, the standard control strategies design fail unfortunately when the system performance is concerned. In the new approach the proposed control strategy proved its effectiveness and high accuracy in terms of its performance compare to the traditional control mechanisms. The simulations results are carried out in an attractive real-time MATLAB/SIMULINK environment and presented in detailed in the last two sections.

REFERENCES

- [1] Irene Martina Jebarani, D, T. Rammohan, Fuzzy Logic based PID Controller for pH Neutralization process, *International Journal of Computer Applications*, vol. 95, no. 6, pp. 36-40, 2014;
- [2] S. Zihlmann, *Modelling of a simple continuous neutralization reactor*, February 2015. Available at <http://thirdway.ch/files/neutralisation/NeutralisationModeling.pdf>, accessed on 16 Feb. 2017;

- [3] Ahmmed Saadi Ibrehem, Modified Mathematical Model For Neutralization System In Stirred Tank Reactor - Research Article, *Bulletin of Chemical Reaction Engineering & Catalysis*, vol. 6, no. 1, pp. 47 – 52, 2011;
- [4] R.Weber, Optimization and Control, Lectures notes Manuscript. Available at <http://www.statslab.cam.ac.uk/~rrw1/oc/La5.pdf> , accessed on 24 Feb. 2017;
- [5] Bo Bernhardsson, K.J. Åström, Control System Design-LQG, Lecture – LQG.ppt, Lund University, <http://www.control.lth.se/media/Education/DoctorateProgram/2016/Control%20System%20Synthesis/lqg.pdf> , accessed on 17 Feb.2017;
- [6] J. M. Athans and P. L. Falb, *Optimal Control: An Introduction to the Theory and Its Applications*, McGraw- Hill, New York, 1996;
- [7] R.M. Murray, Optimization-Based Control, DRAFT Manuscript v2.1a, February 2010, California Institute of Technology. Available at http://www.cds.caltech.edu/~murray/books/AM08/pdf/obc-optimal_04Jan10.pdf , accessed on 17 February 2017;
- [8] G.F. Franklin, J. David Powell, Michael L. Workman, *Digital Control of Dynamic Systems*, Second Edition, ADDISON-WESLEY PUBLISHING COMPANY Series in Electrical and Computer Engineering: Control Engineering, USA, 1990.